



Knitting Free

Patterns for Summer



7 Sizzling Knit Tops, Knit Sweater Patterns & More

ALLFREEKNITTING 

How to Knit a Sweater: 7 Free Sweater Patterns

Copyright 2013 by Prime Publishing LLC

All rights reserved. No part of this book may be reproduced or transmitted in any form or by any means, electronic or mechanical, including photocopying, recording, or by any information storage or retrieval system, without written permission from the publisher, except in the case of brief quotations embodied in critical articles and reviews.

Trademarks are property of their respective holders. When used, trademarks are for the benefit of the trademark owner only.

Published by Prime Publishing LLC, 3400 Dundee Road, Northbrook, IL 60062 – www.primecp.com



[Free Knitting Projects](#)



[Free Crochet Projects](#)



[Free Craft Projects](#)



[Free Holiday Craft Projects](#)



[Free Sewing Projects](#)



[Free Quilt Projects](#)



[Free Jewelry Projects](#)



[Free Christmas Crafts](#)



[Free Crochet Afghan Patterns](#)

COVER PHOTO CREDITS

THANKS TO THE FOLLOWING BLOGGERS AND COMPANIES
FOR THEIR PHOTOS ON OUR EBOOK COVER

[DANA BIDDLE FROM COLOURSPUN](#)
[RED HEART YARN](#)
[KNITTING FEVER](#)

Knitting Free Patterns for Summer: 7 Sizzling Knit Tops, Knit Sweater Patterns & More

Letter from the Editor

Hello Knitters,

Warm weather knitting is one of the pleasures of knitting that can be easily overlooked. It's a well-kept secret that knitting patterns for summer and spring can be just as fun as knitting for cold winter nights—the only thing that changes is the type of garment you knit and the fiber of your yarn! With a good cotton, linen, or silk yarn, knitting in the warm weather can be wonderfully rewarding.

Summer tops are a great break for sweater lovers to tackle. You can get some lace action in your knitting, and you get to leave the sleeves off. There are a lot of things to love about these easy knitting patterns for summer. Simple, wearable, and suitable for knitters of all skill levels, these patterns will make your summer vacations extra special.

For the nights when it gets a little chilly, we've included a couple of stellar knit sweater patterns and a knit shawl or two. These free knitting patterns will make your summer memorable and enjoyable.

Happy knitting!

Sincerely,

Audrey Huggett, Editor for AllFreeKnitting.com

<http://www.AllFreeKnitting.com>

Find blog posts about AllFreeKnitting at StitchandUnwind.com

TABLE OF CONTENTS

Cover Photo Credits	1
Casual Knit Top	4
Designed By: Joanne from Craft Passion	4
Basic Summer Poncho	7
Designed By: Bernat Design Team	7
Desert Lace Shawl	9
Designed By: Karen Klein for Knitting Fever	9
Rosy Cotton Top	11
By: Dana Biddle from ColourSpun	11
Emily Summer Sweater	14
Designed By: Lorna Miser for Red Heart Yarn	14
Four Seasons Knit Vest	20
Designed By: Julie Farmer for Red Heart Yarn	20
Classy Knit Top	24
Designed By: Chris from Chris Knits in Niagra	24
Thank You	27
Thank You	28

CASUAL KNIT TOP

DESIGNED BY: [JOANNE FROM CRAFT PASSION](#)



If you're looking for a loose fit, draping style shirt, then the Casual Knit Top is just for you. This sleeveless top knitting pattern is easy to follow. The finished top layers well on almost any kind of shirt, so it's easy to dress up or down. You can easily wear this in any season; the light, flowing top is perfect for a breezy summer day when paired with a light tank top. This is a one-size-fits-all pattern, so you don't need to worry about sizing your pattern, just cast on and get knitting!

Finished Dimensions

Loose fit, 21" (W) x 31 1/2 "(L)

Materials

- 1,168 yards DK weight yarn
- Knitting Needles: 4.5 mm [US 7]
- Crochet Hook: 4.5 mm – for casting stitches on knitting needles
- Tapestry needle
- White lace thread or light weight yarn

Gauge

In stockinette stitch, 20 sts and 26 rows = 4 inches

Abbreviations

kfb – knit front and back
k2tog – knit 2 together
ssk – slip slip knit
yo – yarn over

Knitting Free Patterns for Summer: 7 Sizzling Knit Tops, Knit Sweater Patterns & More

RS – right side

WS – wrong side

Stockinette Lace Ladders Pattern

1st row (RS) – ssk, (yo) twice, k2tog

2nd row (WS) – p1, (p1, k1) into double yo, p1

Note: you may replace the stockinette lace ladders pattern with normal stockinette stitch if you are not comfortable working in this pattern.

INSTRUCTIONS

Back

With 4.5mm crochet hook, cast on 106 sts on 4.5mm knitting needle.

Starting with a K row, work in stockinette st for 150 rows.

With RS, k3, start 1st row stockinette lace ladders pattern, repeat 25 times, k3.

Continue with 2nd row on WS then repeat for 20 rows with this pattern.

Continue to knit with in stockinette st for another 36 row.

Cast off.

Front

With 4.5mm crochet hook, cast on 110 sts on 4.5mm knitting needle.

Starting with a K row, work in stockinette st and make increment stitch with kfb on the first and the last stitch on RS only, repeat for 140 row. (250 sts)

Work with stockinette st (without increment stitch) for the next 66 row.

Cast off.

Finishing

Steam-block the knitted front and back piece to the correct dimension before joining up.

Join side with mattress stitch for 140 row. Join shoulder with shoulder seam stitch for 37 sts. If you find the yarn is hard to sew, substitute it with white lace thread or light weight yarn.

Gather up part of the shoulder seams to suit your shoulder width.

Gather up one side of side seam.

Loose & Drapery Neck Top

Easy Knitting Pattern

more @ <http://www.craftpassion.com/?p=19523>

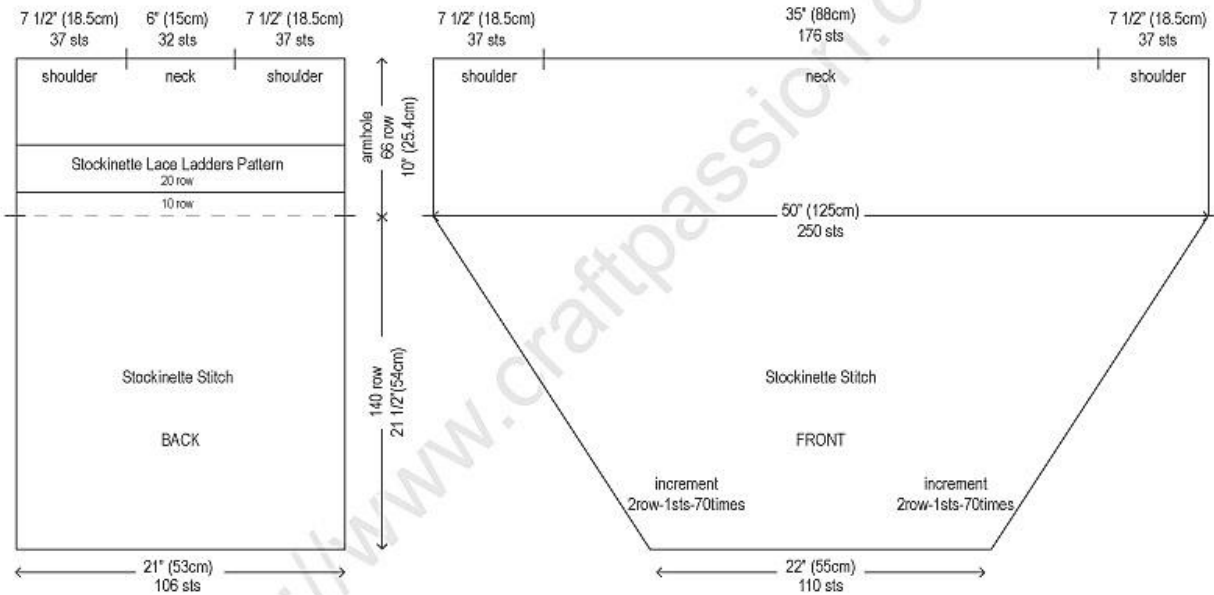

Copyright © craftpassion.com
Meant for hobby and personal use only. Do not sell.

BASIC SUMMER PONCHO

DESIGNED BY: [BERNAT DESIGN TEAM](#)



Get the hang of poncho knitting with this simple pattern that features a basic poncho shape. With lines of lace constructed from delicate yarn, this is one of those free easy knitting patterns that begs to be worn during the summer. To assemble your poncho, knit two rectangles and seam together as shown in the diagram below.

Finished Dimensions

XS/M 28-38 inches [71-96.5 cm]

L/2XL 40-50 inches [101.5-127 cm]

3/5XL 52-62 inches [132-157.5 cm]

Finished Length between neck edge and point

XS/M 22 inches [56 cm]

L/2XL 25 inches [63.5 cm]

3/5XL 30 ½ inches [77.5 cm]

Materials

- Bernat Satin yarn: XS/M (L/2XL-3/5XL) (Solids: 100 g / 3.5 oz) 4 (5-6) balls OR (Ombres: 80 g / 2.8 oz) 5 (7-8) balls
- Wide ribbon 50 ins [127 cm] long for Drawstring (optional).
- Size 5 mm (U.S. 8) knitting needles or size needed to obtain gauge. ½ inch [1.5 cm]

Gauge

In stockinette stitch, 18 sts and 24 rows = 4 inches

Knitting Free Patterns for Summer: 7 Sizzling Knit Tops, Knit Sweater Patterns & More

INSTRUCTIONS

Body

(Make 2 pieces alike).

Cast on 62 (70-86) sts.

Knit 4 rows, noting that first row is WS.

Proceed as follows:

1st row: (WS). K3. Purl to last 3 sts. K3.

2nd row: K2. *K2. yfwd. K2tog. K2. Sl1. K1. pssso. yfwd. Rep from * to last 4 sts. K4.

Rep last 2 rows until work from beg measures 27 (29-33) ins [68.5 (73.5-84) cm], ending with WS facing for next row. Knit 4 rows. Cast off.

Finishing

Sew cast off edge of one piece to the side of other piece as shown in Diagram.

Ribbon Drawstring (optional)

Starting at center front, thread ribbon along neck edge. Tie into a bow at center.

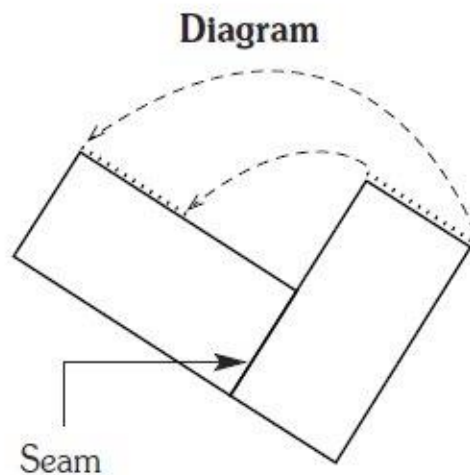

[DESERT LACE SHAWL](#)

DESIGNED BY: [KAREN KLEIN FOR KNITTING FEVER](#)



Sometimes something quick and easy is the best way to go. The Desert Lace Shawl is a wonderfully easy knitting pattern that will have you decked out in knitted glory in almost no time. Whether you're knitting up this simple knit shawl pattern while on your summer vacation or wrapping it around your shoulders at a wedding, this is one project that you'll love to knit and wear.

Finished Dimensions

Approximately 22 x 48 inches after blocking

Materials

- 1 skein (100g) of Knitting Fever's Painted Desert shade #4 Amber
- 2 needles size US 4

Gauge

In stockinette stitch, 4.5 stitches = 1 inch

Abbreviations

pm = place marker

sm = slip marker

yo = yarnover

Knitting Free Patterns for Summer: 7 Sizzling Knit Tops, Knit Sweater Patterns & More

INSTRUCTIONS

Cast on 7 sts

Row 1: k2, yo, k1, yo, pm, k1, pm, yo, k1, yo, k2

Row 2: k2, purl to last 2 sts, k2 (11 sts)

Stockinette Section

Row 3: k2, yo, k to marker, yo, sm, k1, sm, yo, k to last 2 sts, yo, k2

Row 4: k2, purl to last 2 sts, k2

Repeat rows 3 & 4, 10x (55 sts)

Eyelet Section

Row 5: k2, yo, k1, *yo, k2tog, repeat from * to marker, yo, sm, k1, sm, **yo, k2tog, repeat from ** to last 3 sts, yo, k1, yo, k2.

Row 6: k2, purl to last 2 sts, k2

repeat rows 3-4 (stockinette section) 10x, then repeat rows 5-6 (eyelet section) once
repeat from *** to *** until desired length.

Next row: k2, yo, knit to marker, yo, k1, yo, knit to last 2 stitches, yo, k2.

Repeat this row 4x.

Bind off loosely. Block to desired measurements.

ROSY COTTON TOP

BY: DANA BIDDLE FROM COLOURSPUN



This lightweight Rosy Cotton Top is perfect for warmer spring or summer weather. With delicate crochet edging and colorful ribbon strands laced through the back, this knitted sweater is great for both casual and dressy occasions. To adapt this top for winter, simply use heavier wool and the appropriate needles.

Finished Dimensions

(Bust) 38-40inches

Note: If you want your garment bigger or smaller, alter the number of stitches and rows to obtain your required size. Remember that this top is meant to fit loosely.

Materials

- 300g ColourSpun 100% cotton DK in main color
- Other cotton yarn or ribbon for embellishment
- 4.5 mm (US 7) knitting needles
- 4.5 mm crochet hook

Gauge

In stockinette stitch, 16 stitches and 22 rows = 4 inches

Abbreviations

ch = chain stitch

K2tog = knit 2 together

Sc = single crochet

Yo = yarn over

Knitting Free Patterns for Summer: 7 Sizzling Knit Tops, Knit Sweater Patterns & More

INSTRUCTIONS:

Sides and Sleeves - work 2 identical pieces

Pattern: (over 10 rows) Starting with a knit row, work 9 rows in stockinette stitch, k 10th row. Repeat.

Cast on 155 sts and work 45 rows in pattern as set above.

Next row: cast off 29; p 97; c/off 29. End and break off yarn.

Rejoin yarn to sts left on needle and continue in pattern as set; work 34 rows

Next row: cast off.

Back

Cast on 36 sts and work 5 rows stst.

Next row: k5 (yo; k2tog; k4)x5; k1

Next 5 rows: stst

Repeat last 6 rows 16 more times

Cast off.

Front

Cast on 36 sts and work 5 rows stst.

Next row: k5 (yo; k2tog; k4)x5; k1

Next 5 rows: stst

Repeat last 6 rows 12 more times

Cast off.

Assembly

Stitch back and front pieces to side pieces (see photos for reference). Fold garment in half along shoulder line and complete sleeve and side seams.

Knitting Free Patterns for Summer: 7 Sizzling Knit Tops, Knit Sweater Patterns & More

Edging

Work edging around neck, sleeves and bottom.

Using either main or contrasting color, work 2 rounds of sc around edge

Next round – [2sc; (1sc,2ch,1sc)into next st] to end.

Remember to decrease in each neck corner by skipping 1 or 2 sts on rounds 2 and 3 to keep your work flat.

Finishing

Finish your garment by lacing contrasting yarn or ribbon through the holes in the back and front and winding the ends into a rose. Stitch to hold in place.



[EMILY SUMMER SWEATER](#)

DESIGNED BY: [LORNA MISER FOR RED HEART YARN](#)



This simple cardigan is meant to be worn all spring and summer long. Whether you wear the Emily Summer Sweater by itself or as a coat over a sundress, you'll love how the seed stitch edging complements the rest of the stockinette stitch sweater. If you're a beginner knitter, you can easily learn how to knit a sweater too. This is an easy pattern that makes an ideal garment to practice on.

Finished Dimensions

Bust

36 (40, 44, 48, 52) inches

Length

24 (25, 26, 27, 28) inches

Materials

- Red Heart Soft: 5 (6, 7, 8, 8) balls Wheat 9388
- 4mm (US 6) knitting needles
- 4 mm (US 6) – 29 inch circular knitting needle
- Stitch holders
- Six buttons
- Tapestry needle

Gauge

In stockinette stitch, 20 sts and 28 rows = 4 inches

Seed Stitch

Worked over an odd number of sts

Knitting Free Patterns for Summer: 7 Sizzling Knit Tops, Knit Sweater Patterns & More

Row 1 (RS): K1, *K1, P1; repeat from * to last 2 sts, K2

Row 2: P 1, *K1, P1; repeat from * across.

One Row Buttonhole

Bind off 2 sts, replace last st worked to left needle. Cast on 3 sts to right needle. Slip worked st to right needle. Pas 1 cast on st over worked st.

INSTRUCTIONS

Back

Cast on 133 (153, 169, 189, 205) sts.

Work in Seed st for 1", end Row 2.

Change to St st, begin Knit row, and work even until back measures 11" from cast-on, ending after a Purl row.

Empire Shaping

K17 (19, 20, 22, 23), [K3tog] 11 (13, 15, 17, 19) times, K33 (37, 39, 43, 45), [K3tog] 11 (13, 15, 17, 19) times,

K17 (19, 20, 22, 23) – 89 (101, 109, 121, 129) sts.

Work in Seed st for 1", begin Row 2, end Row 2. Change to St st and work even until 5½ (6, 6½, 7, 7½)" above empire shaping, end purl row.

Shape Armholes

Bind off 5 (7, 7, 9, 10) sts at beginning of next 2 rows.

Dec 1 st at each edge every right side row 5 (7, 8, 8, 10) times – 69 (73, 79, 87, 89) sts.
Work even until armhole measures 7½ (8, 8½, 9, 9½)".

Place sts on holder for back neck and shoulders.

Knitting Free Patterns for Summer: 7 Sizzling Knit Tops, Knit Sweater Patterns & More

Left Front

** Cast on 67 (77, 85, 95, 103) sts. Work same as for back until Empire Shaping.

Empire Shaping

K17 (19, 20, 22, 23), [K3tog] 11 (13, 15, 17, 19) times, K17 (19, 20, 22, 23) – 45 (51, 55, 61, 65) sts. Work in Seed st for 1", begin Row 2, end Row 2. Change to St st and work even until 5½ (6, 6½, 7, 7½)" above empire shaping, end purl row. **

Shape Armhole and Neck

Bind off 5 (7, 7, 9, 10) sts at beg of next row for armhole and dec 1 st at end of row for neck.

Dec 1 st at armhole edge every right side row 5 (7, 8, 8, 10) times AND AT THE SAME TIME dec 1 st at neck edge every 4th and 2nd row alternately 16 more times – 18 (20, 23, 27, 28) sts.

Work even until front measures same as back to shoulder.

Place all sts on holder for shoulder.

Right Front

Work same as for left front from ** to **.

Shape Armhole and Neck

Dec 1 st at neck edge at beginning of next Knit row. Bind off 5 (7, 7, 9, 10) sts at beginning of next Purl row.

Dec 1 st at armhole edge every right side row 5 (7, 8, 8, 10) times AND AT THE SAME TIME dec 1 st at neck edge every 4th and 2nd row alternately 16 more times – 18 (20, 23, 27, 28) sts.

Work even until front measures same as back to shoulder.

Place all sts on holder for shoulder.

Knitting Free Patterns for Summer: 7 Sizzling Knit Tops, Knit Sweater Patterns & More

Join Shoulders

Place sts from back and fronts on needles with needle points at arm edge.

Hold pieces with right sides together and beginning at arm edge, insert needle as if to knit into first st on needle in front and then into first st on needle in back, yarn over and draw yarn through both sts at the same time; * insert needle into next st on needle in front and into corresponding st on needle in back, yarn over and draw yarn through both sts, slip first st on right needle over 2nd st and off the needle – one st bound off.

Repeat from * until 18 (20, 23, 27, 28) sts are bound off for shoulder.

Repeat on opposite shoulder leaving center 33 sts on holder for back neck.

Neck and Front Edging

Mark positions for 6 buttonholes along right front edge.

With right side facing and circular needle, pick up and K82 (85, 88, 90, 92) sts up right front to beginning of neck shaping, 37 (40, 43, 45, 48) sts up right neck edge, K33 sts across back neck holder, 37 (40, 43, 45, 48) sts down left neck edge, and 82 (85, 88, 90, 92) sts down left front from beginning of neck shaping to lower edge – 271 (283, 295, 303, 313) sts.

Work in Seed st for ½". Keeping continuity of Seed st, work One Row Buttonhole at each marker.

Continue in Seed st for ½". Bind off. Sew buttons to left front.

Sleeves

Cast on 65 (71, 75, 81, 85) sts. Work in Seed st for 1", end Row 2. Continue in St st, begin Knit row, until sleeve measures 3" from beginning, end Purl row.

Knitting Free Patterns for Summer: 7 Sizzling Knit Tops, Knit Sweater Patterns & More

Shape Armholes

Bind off 5 (7, 7, 9, 10) sts at beginning of next 2 rows.

Dec 1 st at each edge every right side row 19 (20, 22, 23, 24) times – 17 sts. Bind off.

Finishing

Sew side seams. Sew sleeve seams. Set in sleeves.

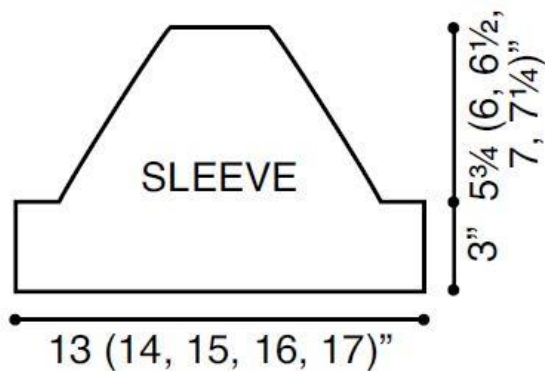

Knitting Free Patterns for Summer: 7 Sizzling Knit Tops, Knit Sweater Patterns & More

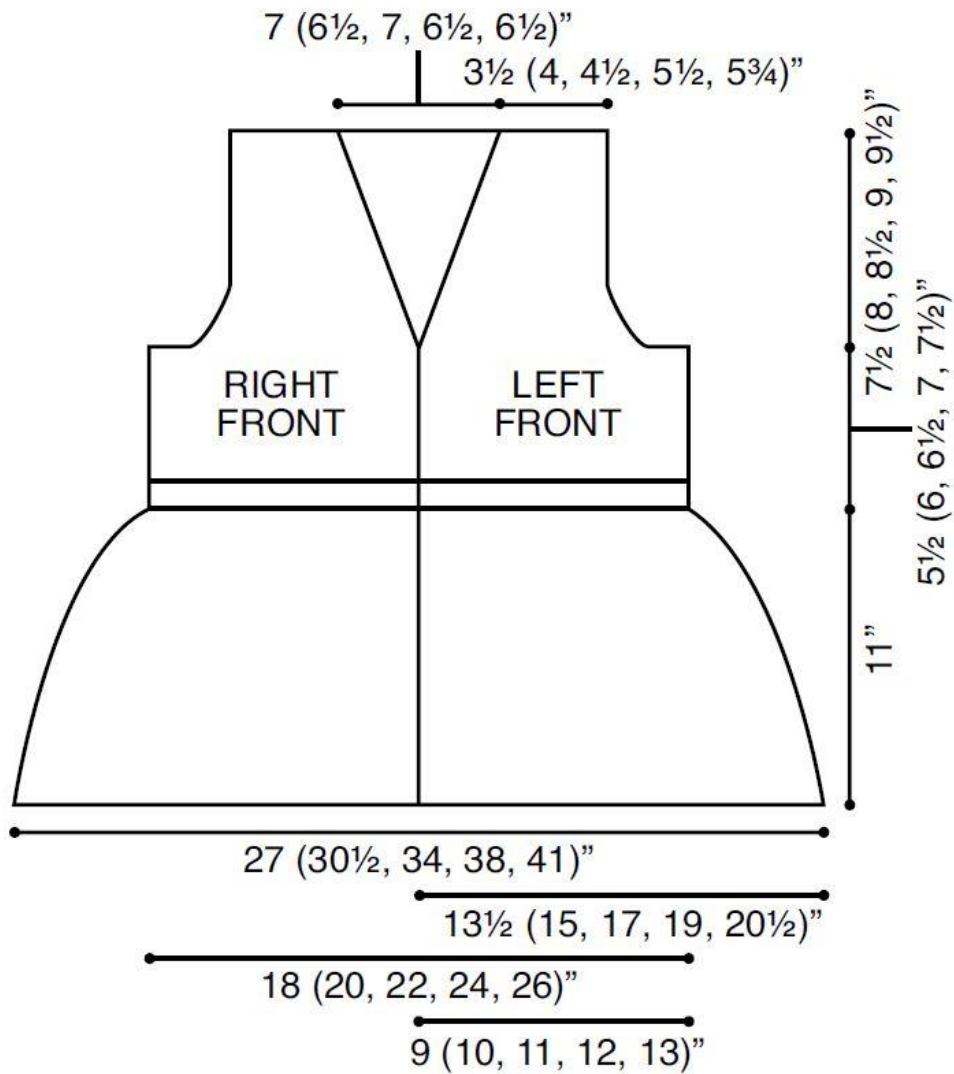

[FOUR SEASONS KNIT VEST](#)

DESIGNED BY: [JULIE FARMER FOR RED HEART YARN](#)



This simple mesh vest is just what you need to gear up for spring and summer. With delicate texture and shape, the Four Seasons Knit Vest can easily be worn during colder months, too - just add layers! Have fun mixing and matching different pieces from your closet using this knit vest pattern.

Finished Dimensions

Bust

28 (32, 36, 40, 44, 48) inches

Length

19 ½ (19 ½, 22, 22, 23 ½, 23 ½) inches

Materials

- Red Heart Stardust: 3 (3, 4, 5, 6, 6) balls Green 1623
- 5.5 mm (US 9) knitting needles
- 4 mm (US G-6) crochet hook
- Tapestry needle

Gauge

In Mesh Pattern, 16 sts and 24 rows = 4 inches

Mesh Pattern

Row 1 (Wrong Side): *K2tog, [yo] twice, k2tog; repeat from * to end of row.

Knitting Free Patterns for Summer: 7 Sizzling Knit Tops, Knit Sweater Patterns & More

Row 2: *K2, p1, k1; repeat from * to end of row.

Row 3: K2, *k2tog, [yo] twice, k2tog; repeat from * to last 2 sts, k2.

Row 4: K2, *k2, p1, k1; repeat from * to last 2 sts, k2.

Repeat Rows 1–4 for Mesh Pattern.

INSTRUCTIONS

Back

Cast on 56 (64, 72, 80, 88, 96) sts. Work in Mesh Pattern for 68 (68, 68, 76, 80, 80) rows.

Shape Armholes

Row 1: Bind off 4 (4, 4, 4, 8, 8) sts, continue in Row 1 of Mesh Pattern to end of row—52 (60, 68, 76, 80, 88) sts.

Row 2: Bind off 4 (4, 4, 4, 8, 8) sts, continue in Row 2 of Mesh Pattern to end of row—48 (56, 64, 72, 72, 80) sts.

Beginning with Row 3 of pattern, work in Mesh Pattern for 46 (46, 54, 54, 58, 58) more rows.

Bind off loosely.

Left Front

Cast on 56 (64, 72, 80, 88, 96) sts. Work in Mesh Pattern for 68 (68, 68, 76, 80, 80) rows.

Shape Armholes

Row 1: Work Row 1 of Mesh Pattern.

Row 2 (Right Side): Bind off 4 (4, 4, 4, 8, 8) sts, continue in Row 2 of Mesh Pattern to end of row—52 (60, 68, 76, 80, 88) sts.

Beginning with Row 3 of pattern, work in Mesh Pattern for 46 (46, 54, 54, 58, 58) more rows.

Knitting Free Patterns for Summer: 7 Sizzling Knit Tops, Knit Sweater Patterns & More

Bind off loosely.

Right Front

Cast on 56 (64, 72, 80, 88, 96) sts. Work in Mesh Pattern for 68 (68, 68, 76, 80, 80) rows.

Shape Armhole

Row 1 (Wrong Side): Bind off 4 (4, 4, 4, 8, 8) sts, continue in Row 1 of Mesh Pattern to end of row—52 (60, 68, 76, 80, 88) sts.

Beginning with Row 2 of pattern, work in Mesh Pattern for 47 (47, 55, 55, 59, 59) more rows.

Bind off loosely.

Finishing

Block pieces to measurements shown on schematic.

Beginning at armhole edge, sew shoulder seams for 3 (4, 4½, 5, 5, 5½)". Sew side seams.

Armhole Edging

With Right Side facing and crochet hook, join yarn with single crochet at underarm, single crochet evenly spaced around armhole; join with slip st in first sc. Fasten off. Repeat around other armhole.

Weave in ends.

Knitting Free Patterns for Summer: 7 Sizzling Knit Tops, Knit Sweater Patterns & More

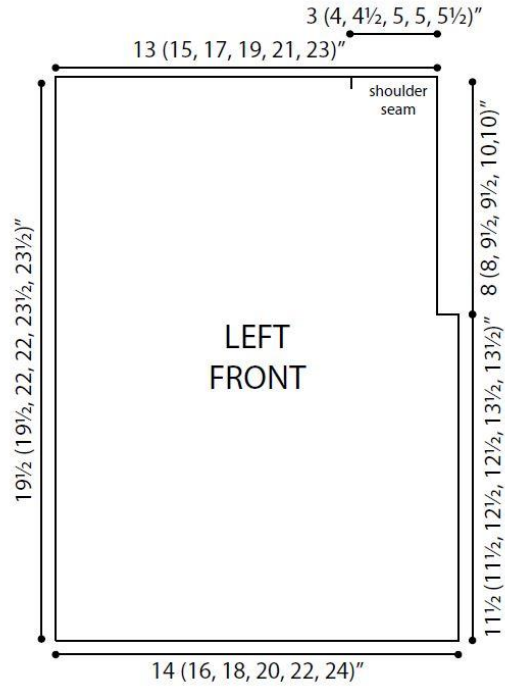
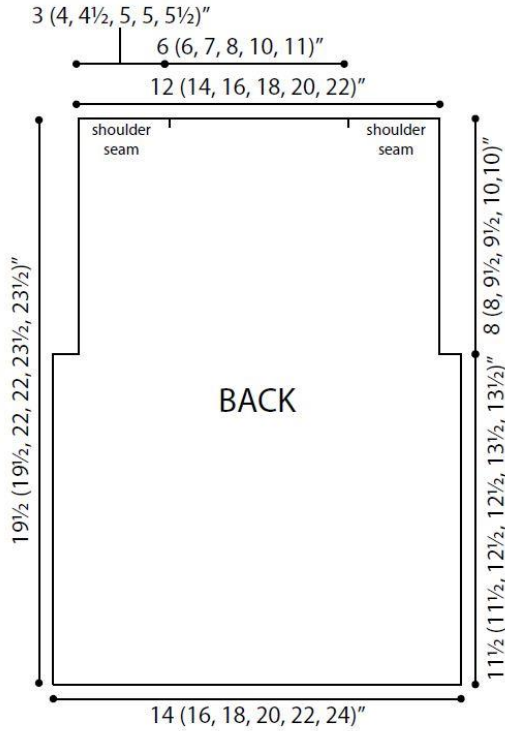

CLASSY KNIT TOP

DESIGNED BY: [CHRIS FROM CHRIS KNITS IN NIAGRA](#)



You can go far with this versatile Classy Knit Top. Wear it up as a sedate sweater vest, or wear it alone as a tank. A cute beaded pattern is worked into the top to give it additional texture and sparkle. Use a cotton yarn to make this knitted top pattern a wonderful addition to your summer wardrobe. If you're thinking about making a sweater, this knitted vest pattern is a great intermediate step since you don't have to worry about making sleeves.

Finished Dimensions

32[34, 36, 39, 41, 44] inches at bust line, approx. sizes 4[6,8,10,12,14+] Circle the size you need to knit throughout the pattern.

Materials

- Rowan Wool Cotton: 6[6,6,7,7,8] balls in citron—DK weight 123 yards per 50 gram ball.
- 4mm (US 6) knitting needles
- Glass beads, large enough to thread on the yarn (optional)

Gauge

In stockinette stitch, 20 sts and 25 rows = 4 inches

Knitting Free Patterns for Summer: 7 Sizzling Knit Tops, Knit Sweater Patterns & More

INSTRUCTIONS

Back

With 4mm needles, cast on 80[86, 89, 95, 101, 110] sts. Work in K2, P1 ribbing, end with K2. Keep to this ribbing, for 6[6, 6, 6.5, 7, 7] inches. Right side facing: place beads in this row as follows: Break yarn and thread 26[28, 29, 31, 33, 36] beads onto the yarn. Join again and K2, slip purl stitch onto right hand needle AND slide a bead along the yarn to sit IN FRONT of this slipped stitch, then Knit next two knit stitches. Continue to slip the purls and slide a bead in front, then knit 2, until row and beads are done.

Next Row: Purl across all stitches.

Continue in stocking stitch (knit the right side, purl the wrong side, until 12[12.5, 13, 13, 13.5, 14] inches have been worked from the start.

Shape armholes: Cast off 7[7,7,8,8,9] stitches from the start of the next two rows. Decrease one each side on the right sides seven times. Work even until piece measures 27[27,28,29,30,30] inches. Cast off all stitches.

Front

Work the same as the back, including the bead placement at the top of the ribbing. When all the Armhole decreases have been worked, add the front bead details as follows: Break yarn and thread 10 beads onto yarn, then join again.

Bead Install Increase Row 1: Right side: Knit 15, yarn over needle, knit to last 15 sts, yarn over needle, knit 15. (keep sliding beads along yarn until ready to "install")...

Row 2: Wrong side: P 15, slip the yarn-over stitch AND slide bead into position IN FRONT (you are working from the back, so make sure it is on the front side), Purl to next yarn over, and slip that one while adding a bead, then purl the last 15. (Two beads added over the yarn-over spots, and two stitches have been added.) See detail in photo below.

Work 4 rows straight of stocking stitch, then repeat the right and wrong side bead installing rows. Do this 6 row pattern until 10 beads have been added, then work even until same length as back. Cast off all stitches. The front will be 10 stitches wider between the bead lines, and this adds a drape to the boat neck so it is not too snug in front. The excess will roll a bit more than the back!

Knitting Free Patterns for Summer: 7 Sizzling Knit Tops, Knit Sweater Patterns & More

Sew the shoulders

Stitch together the outside 15 stitches on the front and back and leave the ones between the beads, and the matching space on the back to roll naturally into an interesting neckline. Pick up 93[96, 96, 102, 105, 109] stitches around the armholes and work in k2, p1 ribbing for two rows, then cast off in ribbing. Join side seams.



Knitting Free Patterns for Summer: 7 Sizzling Knit Tops, Knit Sweater Patterns & More

THANK YOU

THE FOLLOWING BLOGGERS MADE THIS ECOOKBOOK POSSIBLE:



Joanne from [Craft Passion](#)



BERNAT[®]

[Bernat](#)



[Knitting Fever](#)



ColourSpun
natural designer yarn

Danna from [ColourSpun](#)



[Red Heart Yarn](#)

Knitting Free Patterns for Summer: 7 Sizzling Knit Tops, Knit Sweater Patterns & More

THANK YOU

THE FOLLOWING BLOGGERS MADE THIS ECOOKBOOK POSSIBLE:

Chris Knits in Niagara

Original patterns, comments and works in progress, all from Chris' knitted world.

Chris from [Chris Knits in Niagara](#)