



New Favorites from

Lion Brand



15 Free Knitting Patterns for Scarves, Afghans, and More!



New Favorites from Lion Brand: 15 Free Knitting Patterns for Scarves, Afghans, and More

Copyright 2013 by Prime Publishing LLC

All rights reserved. No part of this book may be reproduced or transmitted in any form or by any means, electronic or mechanical, including photocopying, recording, or by any information storage or retrieval system, without written permission from the publisher, except in the case of brief quotations embodied in critical articles and reviews.

Trademarks are property of their respective holders. When used, trademarks are for the benefit of the trademark owner only.

Published by Prime Publishing LLC, 3400 Dundee Road, Northbrook, IL 60062 www.primecp.com

ALLFREEKNITTING 
Free Knitting Patterns For Happy Stitching

Knit Picky Patterns

ALLFREECROCHET 
"Free Crochet Patterns For Happy Hooking"

favecrafts   

AllFreeHolidayCrafts    
Creations and Celebrations for Every Occasion

ALLFREESEWING 
Free Patterns To Keep You In Stitches

FAVEQUILTS 
Quilts, Fabric, and More

ALLFREEJEWELRYMAKING 
Your Go-To Source for DIY Jewelry Inspiration

ALLFREECHRISTMASCRAFTS 
Create The Christmas Of Your Dreams

ALLFREEKIDSCRAFTS 
Explore. Imagine. Create.

ALLFREECROCHETAFGHANPATTERNS
Your #1 Source for Free Crochet Afghan Patterns

ALLFREEDIYWEDDINGS   
"Do It Yourself Ideas For Your Special Day"

ALLFREEPAPERCRAFTS 
"Nothing Is A Waste Of Paper"

Dear Reader,

Lion Brand Yarn Company is a business that has been family-owned and operated for five generations. This year marks our 135th anniversary, and we're celebrating a long history of inspiration, education, and innovation. Our company is devoted to supporting and encouraging you with yarns, patterns, how-tos and ideas.

For this collection, we've hand-picked 15 of our favorite knitting patterns from our new design catalog. They range in skill level from beginner to experienced, from large projects to small. You can view all 5000 of our patterns online at LionBrand.com.

Our yarns, which are featured in the patterns we've selected here for you, are available at major retail and craft chains nationwide, as well as on our website.

We release new patterns all the time, and our newsletter subscribers are the first to know about new yarns, colorways, and craft trends. Visit LionBrand.com to sign up for our newsletter today.

With warm regards,

Lion Brand Yarn

www.LionBrand.com

About Lion Brand:

Since 1878 Lion Brand has been creating quality yarns at affordable prices—and helping knitters and crocheters turn them into fabulous fashion statements. Whether your style is classic or cutting edge, we've got a pattern that's just right for you. And with more than 800 fashion forward colors and over 60 fabulous fibers to choose from you're sure to find the look you love.

We know that knitting and crochet is more than just a hobby—it's a soul soothing, style-satisfying means of creative expression. Our highest priority is to support you in every way possible to ensure your satisfaction through full customer service, support by email and phone, and an active online presence —we're with you every stitch of the way.

LionBrand.com is your go-to resource for thousands of free patterns, tips, tutorials, videos and other learning tools, as well as charity and club finders. Get a behind-the-scenes look into this family-owned company at the Lion Brand's blog (blog.lionbrand.com) or listen to pattern recommendations, exclusive interviews, and great tips with the YarnCraft podcast (yarncraft.lionbrand.com). You can also [@lionbrand yarn](https://twitter.com/lionbrand yarn), [become a fan on Facebook](https://www.facebook.com/lionbrand yarn), or [join us on Pinterest](https://www.pinterest.com/lionbrand yarn). Everywhere you find us, we are ready to help you enjoy your yarn crafting.



New Favorites from Lion Brand: 15 Free Knitting Patterns for Scarves, Afghans, and More

Table of Contents

Knit Scarves and Cowls

Two Ball Twirly Scarf	5
Entrelac Cowl.....	8
Paintbox Scarf.....	14

Sweaters & Cardigans

Cozy Textured Pullover	19
Cozy Hooded Poncho	24
Easy Color Hoodie	30
Chic Baby Cardigan.....	37

Cozy Knit Afghans

Half Square Triangle Blanket.....	42
Mountain Mists Afghan.....	45
Slip Stitch Afghan	48

Hats, Shawls and Tops

Amazing Mitered Shawl	52
Simple Lace Shawl	56
Color Waves Tank Top.....	59
Driggs Avenue Hattitude	65
Positively Red Hook Hat	68

Two Ball Twirly Scarf

By: Lion Brand Design Team



Materials:

- LION BRAND IMAGINE (Art. #515), #309 Strawberry Fields 2 hanks or color of your choice
- LION BRAND knitting needles size 11 (8 mm)

Note: Imagine is a loosely woven, tubular yarn. Knitting with Imagine requires a special, yet simple, technique. The stitches are formed by inserting the needle into this yarn, rather than wrapping the yarn over your needle.

Size: About 6 x 51 in. (15 x 129.5 cm)

Gauge: EXACT GAUGE IS NOT ESSENTIAL TO THIS PROJECT.

SCARF

To cast on, insert your needle into the yarn about 2 in. (5 cm) from the end of the yarn.

Pick up 2-3 threads of the yarn with your needle.

This loop of threads on your needle counts as the first stitch. Insert your needle into the yarn about 2 1/2 in. (6.5 cm) past the first stitch.

Pick up 2-3 threads of the yarn, this is the second stitch.

Repeat once more so that you have 3 stitches (loops) on your needle.

Row 1: Hold the needle containing the stitches in your left hand. Knit across the row as follows:

1. Insert right hand needle into the first stitch on left hand needle and then into the yarn, picking up 2-3 threads of yarn as before to make a new loop on your right hand needle.
2. Pull this new loop back through the existing loop, dropping the existing loop from your left hand needle – one stitch knit.
3. Repeat to knit the remaining 2 stitches.



Repeat Row 1 to knit more rows, until almost all yarn in the first ball has been used.

Knot the end of the second ball of yarn to the first ball of yarn, then continue to repeat Row 1 until about 20 in. (51 cm) of yarn remains.

Bind off by knitting the first, then the second stitch; with the tip of the left hand needle, lift the first stitch over the second and off the needle.

Knit the third stitch, then lift the second stitch over the third. To finish, pull the yarn end through the last stitch.

FINISHING

Knot all yarn ends, then trim close to knot.

Every effort has been made to produce accurate and complete instructions. We cannot be responsible for variance of individual knitters or crocheters, human error, or typographical mistakes.

©2013 Lion Brand Yarn Company, all rights reserved.



Imagine
a versatile new yarn
that allows you to
knit, crochet or craft
a scarf in a flash!



Discover inspiration, how-tos, and thousands of free patterns at LionBrand.com.

LionBrand.com

Entrelac Cowl

By: Lion Brand Design Team



Size: Finished Circumference: About 28 in. (71 cm);

Finished Height: About 7 1/2 in. (19 cm)

Gauge: 18 sts + 24 rows = 4 in. (10 cm) in St st (k on RS, p on WS). BE SURE TO CHECK YOUR GAUGE.

When you match the gauge in a pattern, your project will be the size specified in the pattern and the materials specified in the pattern will be sufficient. If it takes you fewer stitches and rows to match the gauge, try using a smaller size hook or needles; if more stitches and rows, try a larger size hook or needles.

Materials:

- LION BRAND WOOL-EASE (Art. #620)
 - #152 Oxford Grey 1 ball (A)
 - #151 Grey Heather 1 ball (B)
 - #402 Wheat 1 ball (C)
 - or colors of your choice
- LION BRAND knitting needles size 8 (5 mm)
- LION BRAND split ring stitch markers
- LION BRAND® large-eyed blunt needle

Stitch explanations

kfb (knit into front and then back) - An increase worked as follows:

1. Knit the next st through the front loop, but do not remove the st from your left-hand needle.
2. Knit the same st once more, this time inserting your needle through the back loop of the st. You will have created 2 loops (sts) on your right-hand needle.
3. Drop the st from your left-hand needle – you have increased 1 st.

ssk (slip, slip, knit) - Slip next 2 sts as if to knit, one at a time, to right needle; insert left needle into fronts of these 2 sts and knit them tog – 1 st decreased.

Abbreviations

beg = begin(ning)
k = knit
p = purl
p2tog = purl 2 together
pm = place marker
rep = repeat

RS = right side
sl = slip
st(s) = stitch(es)
St st = Stockinette stitch
tog = together
WS = wrong side



Notes

1. Entrelac knitting consists of rows of triangles and blocks that are worked in short rows. Short rows are rows that are worked over a portion of the sts in a row, leaving the remaining sts unworked. To work short rows, the pattern instructions will tell you to 'turn' before you reach the end of the row.
2. Follow the instructions for each row carefully and be sure to keep track of your place in the pattern.
3. Stitch markers are used to make it easier to see the beginning and end of each short row triangle or block. Move the position of the markers following the pattern instructions, being careful to move the beg of the row marker or the end of row marker as specified in the pattern. Use different color markers so that you can distinguish the beg of the row marker from the end of the row marker.
4. The Cowl begins with a section of foundation triangles, then half triangles and blocks are worked. To finish the Cowl, a section of finishing triangles is worked.
5. Unless otherwise noted, slip all sl sts as if to purl.

COWL

With A, cast on 24 sts.

FOUNDATION TRIANGLE SECTION

Foundation Triangle 1

Row 1 (WS): Sl 1, p1, turn.

Row 2 and all RS rows: K to end of row.

Row 3: Sl 1, p2, place marker (pm), turn.

Row 5: Sl 1, p2 (to marker), remove marker, p1, pm, turn.

Row 7: Sl 1, p3 (to marker), remove marker, p1, pm, turn.

Row 9: Sl 1, p4 (to marker), remove marker, p1, pm, turn.

Row 11: Sl 1, p5 (to marker), remove marker, p1, pm, turn.

Row 13: Sl 1, p6 (to marker), remove marker, p1, pm (for beg of next triangle), **DO NOT TURN.**

Foundation Triangles 2 and 3

Row 1 (WS): Sl 1, p1, turn.

Row 2 and all RS rows: K all sts of this triangle (to beg marker), turn. Remove beg marker at end of Row 12.

Row 3: Sl 1, p2, pm, turn.

Row 5: Sl 1, p2 (to marker), remove marker, p1, pm, turn.

Row 7: Sl 1, p3 (to marker), remove marker, p1, pm, turn.

Row 9: Sl 1, p4 (to marker), remove marker, p1, pm, turn.

Row 11: Sl 1, p5 (to marker), remove marker, p1, pm, turn.

Row 13: Sl 1, p6 (to marker), remove marker, p1, pm (for beg of next triangle), **DO NOT TURN.**

Rep Rows 1-13 one more time – you will have made a total of 3 foundation triangles. Do not place a marker at the end of the last rep of Row 13, **TURN.**

Change to B.

Right-Edge Half Triangle

Row 1 (RS): K2, turn.

Row 2 and all WS rows: P to end of row.

Row 3: Kfb, pm, ssk, turn.

Row 5: Kfb, k1 (to marker), ssk, turn.

Row 7: Kfb, k2 (to marker), ssk, turn.

Row 9: Kfb, k3 (to marker), ssk, turn.

Row 11: Kfb, k4 (to marker), ssk, turn.

Row 13: Kfb, k5 (to marker), remove marker, ssk, pm (for beg of next square), **DO NOT TURN**.

The Right-Edge Half Triangle is complete. Leave 8 sts on right-hand needle.

Right Side Blocks

Row 1 (RS): Pick up and knit 8 sts along edge of next foundation triangle, turn.

Row 2: P1, pm, p7 (to beg marker), turn.

Row 3 and all RS rows: Sl 1, k6 (to marker), ssk, turn.

Row 4 and all WS rows: P8 (to beg marker), turn.

Rep Rows 3 and 4 six more times.

Row 17: Remove beg marker, sl 1, k6, remove marker, ssk, **DO NOT TURN**. Place marker at end of Row 17 (for beg of next block).

Rep Rows 1-17 one more time – 2 Right Side Blocks have been completed.

Left-Edge Half Triangle

Row 1 (RS): Pick up and k 8 sts along edge of last foundation triangle, turn.

Row 2: P2tog, p6 (to beg marker), turn.

Row 3 and all RS rows: Sl 1, k to end of row.

Row 4: P2tog, p5 (to beg marker), turn.

Row 6: P2tog, p4 (to beg marker), turn.

Row 8: P2tog, p3 (to beg marker), turn.

Row 10: P2tog, p2 (to beg marker), turn.

Row 12: P2tog, p1, remove marker, turn.

Change to C.

Row 13: P2tog using C, **DO NOT TURN** – 1 st remaining on right-hand needle.

First Wrong Side Block

Row 1 (WS): Pick up and purl 7 sts along edge of triangle just worked (for a total of 8 sts on right-hand needle), turn.

Row 2: K1, pm, k7, turn.

Row 3 and all WS rows: Sl 1, p6 (to marker), p2tog, turn.

Row 4 and all RS rows: K to end of row.

Rep Rows 3 and 4 six more times.

Row 17: Sl 1, p6, remove marker, p1, pm (for beg of next square), **DO NOT TURN**.

Next Wrong Side Blocks

Row 1 (WS): Pick up and purl 8 sts along upper edge of next block.

Discover inspiration, how-tos, and thousands of free patterns at LionBrand.com.



Wool-Ease®

a beloved classic that combines the warmth of wool with the easy-care of acrylic.



LionBrand.com

Row 2: K1, pm, k7 (to beg marker), turn.

Row 3 and all WS rows: Sl 1, p6 (to marker), p2tog, turn.

Row 4 and all RS rows: K8 (to beg marker), turn.

Rep Rows 3 and 4 six more times.

Row 17: Sl 1, p6, remove marker, p1, pm (for beg of next square), **DO NOT TURN.**

Rep Rows 1-17 one more time – 3 Wrong Side Blocks have been completed. Do not place marker at end of last Row 17, **TURN.**

Change to A.

Rep from Right-Edge Half Triangle (working Right Side Blocks and Left-Edge Half Triangle across edges of blocks instead of foundation triangles), work in following color sequence: *A, B, C; rep from * until Cowl measures approximately 28 in. (71 cm) from beginning, end with a row of Right Side Blocks and Left-Edge Half Triangle using C.

Change to A before Row 17 of last Left-Edge Half Triangle – 1 st remaining on right-hand needle. **DO NOT TURN.**

Finishing Triangle 1

Row 1 (WS): Pick up and p 7 sts along edge of triangle just worked (for a total of 8 sts on right-hand needle), turn.

Row 2 and all RS rows: K to end of row.

Row 3: P2tog, p5, pm, p2tog, turn.

Row 5: P2tog, p4 (to marker), p2tog, turn.

Row 7: P2tog, p3 (to marker), p2tog, turn.

Row 9: P2tog, p2 (to marker), p2tog, turn.

Row 11: P2tog, p1 (to marker), p2tog, turn.

Row 13: P2tog, remove marker, p2tog, turn.

Row 15: P2tog, p2tog, pass 1st st over 2nd st – 1 st remaining on right-hand needle. **DO NOT TURN.**

Finishing Triangles 2 and 3

Row 1 (WS): Pick up and p 7 sts along upper edge of next block (for a total of 8 sts on right-hand needle), turn.

Row 2 and all RS rows: K to end of row.

Row 3: P2tog, p5, pm, p2tog, turn.

Row 5: P2tog, p4 (to marker), p2tog, turn.

Row 7: P2tog, p3 (to marker), p2tog, turn.

Row 9: P2tog, p2 (to marker), p2tog, turn.

Row 11: P2tog, p1 (to marker), p2tog, turn.

Row 13: P2tog, remove marker, p2tog, turn.

Row 15: P2tog, p2tog, pass 1st st over 2nd st – 1 st remaining on right-hand needle. **DO NOT TURN.**

Rep Rows 1-15 one more time – 3 Finishing Triangles have been completed.

Fasten off remaining stitch.

FINISHING

Sew cast on edge to finishing edge to make Cowl. Weave in ends.

Every effort has been made to produce accurate and complete instructions. We cannot be responsible for variance of individual knitters or crocheters, human error, or typographical mistakes.

©2013 Lion Brand Yarn Company, all rights reserved.



Get More FREE Patterns from Lion Brand Yarns

[The Most Popular Patterns for Afghans: 16 Knit & Crochet Patterns from Lion Brand](#)

In this inspiring collection of patterns, you'll discover 16 of Lion Brand's most popular patterns for afghans as chosen by the public. Explore Lion Brand's wide variety of yarns that feature a fearless color palette and attractive textural qualities as you knit or crochet your way through this selection of patterns. From beginner to advanced, every knitter and crocheter will find a project that's suited to their needs, regardless of skill level.

[Download Your Free Copy NOW](#)

Paintbox Scarf

By: Lion Brand Design Team



Size: About 9 1/2 x 66 in. (24 x 167.5 cm)

Materials:

- LION BRAND VANNA’S CHOICE (Art. #860)
 - #109 Colonial Blue 1 ball (A)
 - #145 Eggplant 1 ball (B)
 - #147 Purple 1 ball (C)
 - #107 Sapphire 1 ball (D)
 - #134 Terracotta 1 ball (E)
 - #113 Scarlet 1 ball (F)
 - #172 Kelly Green 1 ball (G)
 - #174 Olive 1 ball (H)
 - #153 Black 1 ball (I)
- or colors of your choice
- LION BRAND® knitting needles size 8 (5 mm)
- LION BRAND large-eyed blunt needle

Gauge: 19 sts = about 4 in. (10 cm) in St st (k on RS, p on WS). BE SURE TO CHECK YOUR GAUGE.

When you match the gauge in a pattern, your project will be the size specified in the pattern and the materials specified in the pattern will be sufficient. If it takes you fewer stitches and rows to match the gauge, try using a smaller size hook or needles; if more stitches and rows, try a larger size hook or needles.

Notes

1. Scarf is worked in intarsia colorwork. Do not carry unused color(s) across WS of work. Use a separate ball for each block of color. When changing color, pick up new strand from under dropped strand to twist yarns and prevent holes from forming in your work.
2. Scarf can be worked from written instructions or by following the chart. When following chart, work in St st (k on RS, p on WS). When working from chart, read RS rows on chart from right to left and WS rows from left to right.

Abbreviations

- k** = knit
- p** = purl
- rep** = repeat
- RS** = right side
- st(s)** = stitch(es)
- St st** = Stockinette st
- WS** = wrong side



SCARF

With C, cast on 36 sts.

Row 1 (RS): With C, k6; with D, k30.

Row 2: With D, p30; with C, p6.

Rows 3-8: Rep Rows 1 and 2.

Row 9: With C, k12; with D, k24.

Row 10: With D, p24; with C, p12

Rows 11-16: Rep Rows 9 and 10.

Row 17: With C, k18; with D, k18.

Row 18: With D, p18; with C, p18.

Rows 19-24: Rep Rows 17 and 18.

Row 25: With C, k24; with D, k12.

Row 26: With D, p12; with C, p24.

Rows 27-32: Rep Rows 25 and 26.

Row 33: With C, k30; with D, k6.

Row 34: With D, p6; with C, p30.

Rows 35-40: Rep Rows 33 and 34.

Cut D.

Rows 41-48: With C, work in St st (k on RS, p on WS) for 8 rows.

Cut C.

Rows 49-56: With B, continue in St st for 8 rows.

Row 57: With B, k30; with F, k6.

Row 58: With F, p6; with B, p30.

Rows 59-64: Rep Rows 57 and 58.

Row 65: With B, k24; with F, k12.

Row 66: With F, p12; with B, p24.

Rows 67-72: Rep Rows 65 and 66.

Row 73: With B, k18; with F, k18.

Row 74: With F, p18; with B, p18.

Rows 75-80: Rep Rows 73 and 74.

Row 81: With B, k12; with F, k24.

Row 82: With F, p24; with B, p12.

Rows 83-88: Rep Rows 81 and 82.

Row 89: With B, k6; with F, k30.

Row 90: With F, p30; with B, p6.

Rows 91-96: Rep Rows 89 and 90.

Cut B and F.

Rows 97-144: Work same as Rows 1-48 using H instead of C and E instead of D.

Rows 145-192: Work same as Rows 49-96 using G instead of B and A instead of F.
Rep Rows 1-192 once more.

Bind off.

Discover inspiration, how-tos, and thousands of free patterns at LionBrand.com.



Vanna's Choice®

an easy-care, silky-soft
premium acrylic
in over 60 of your
favorite colors



LionBrand.com

FINISHING

Top and Lower Borders

From RS with I, pick up and k36 sts evenly spaced across one short end of Scarf.

Work in Garter st (k every row) for 1 in. (2.5 cm). Bind off.

Rep across other short end of Scarf.

Side Borders

From RS with I, working across one long side of Scarf, pick up and k4 sts evenly spaced across edge of top border, 280 sts evenly spaced across side edge of Scarf, 4 sts evenly spaced across edge of lower border – 288 sts. **Note:** To pick up and k280 sts evenly spaced across long edge, pick up and k35 sts for every 48 rows. Work in Garter st for 1 in. (2.5 cm).

Bind off. Rep across other long side of Scarf.

Weave in ends.

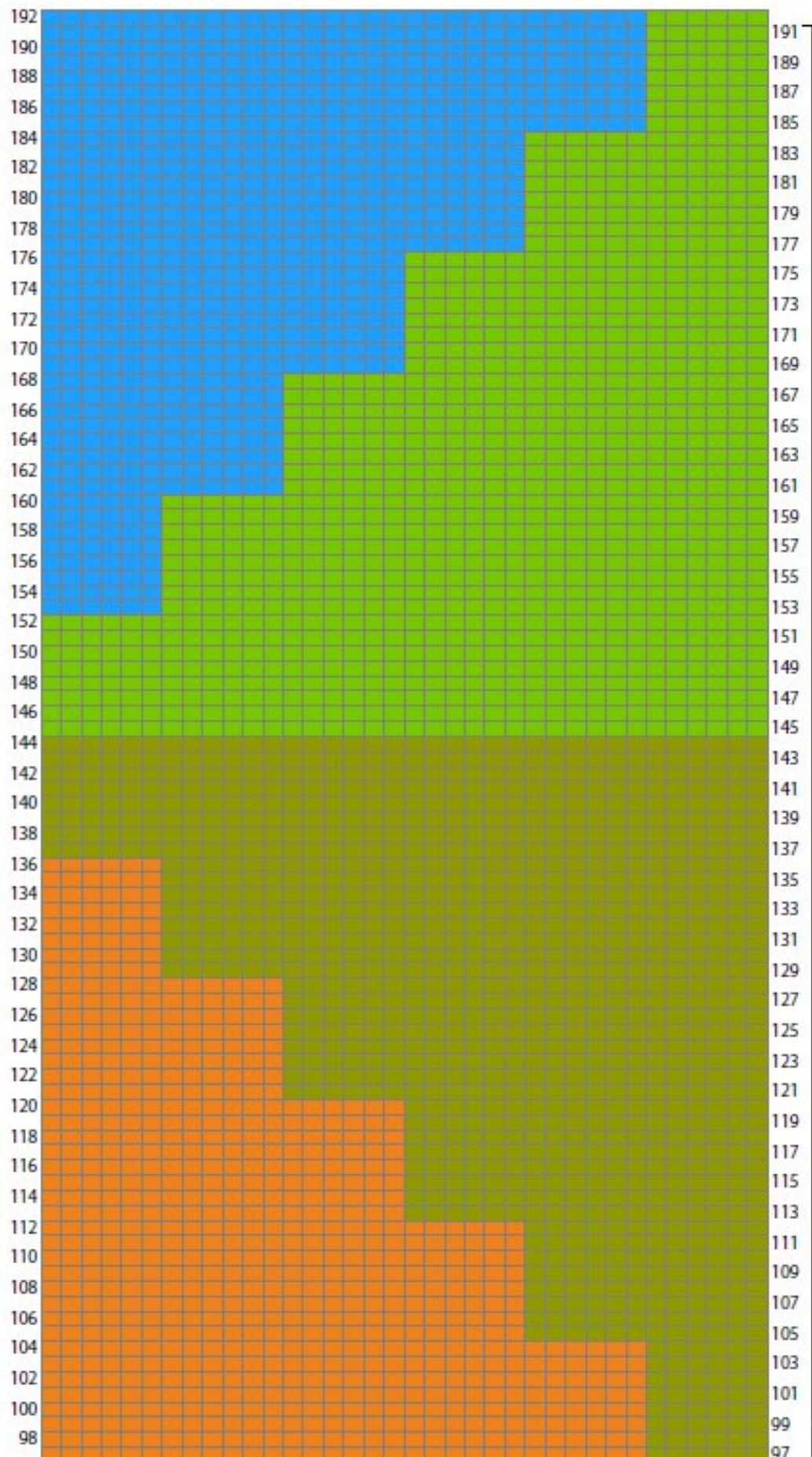

Every effort has been made to produce accurate and complete instructions. We cannot be responsible for variance of individual knitters or crocheters, human error, or typographical mistakes.

©2013 Lion Brand Yarn Company, all rights reserved.

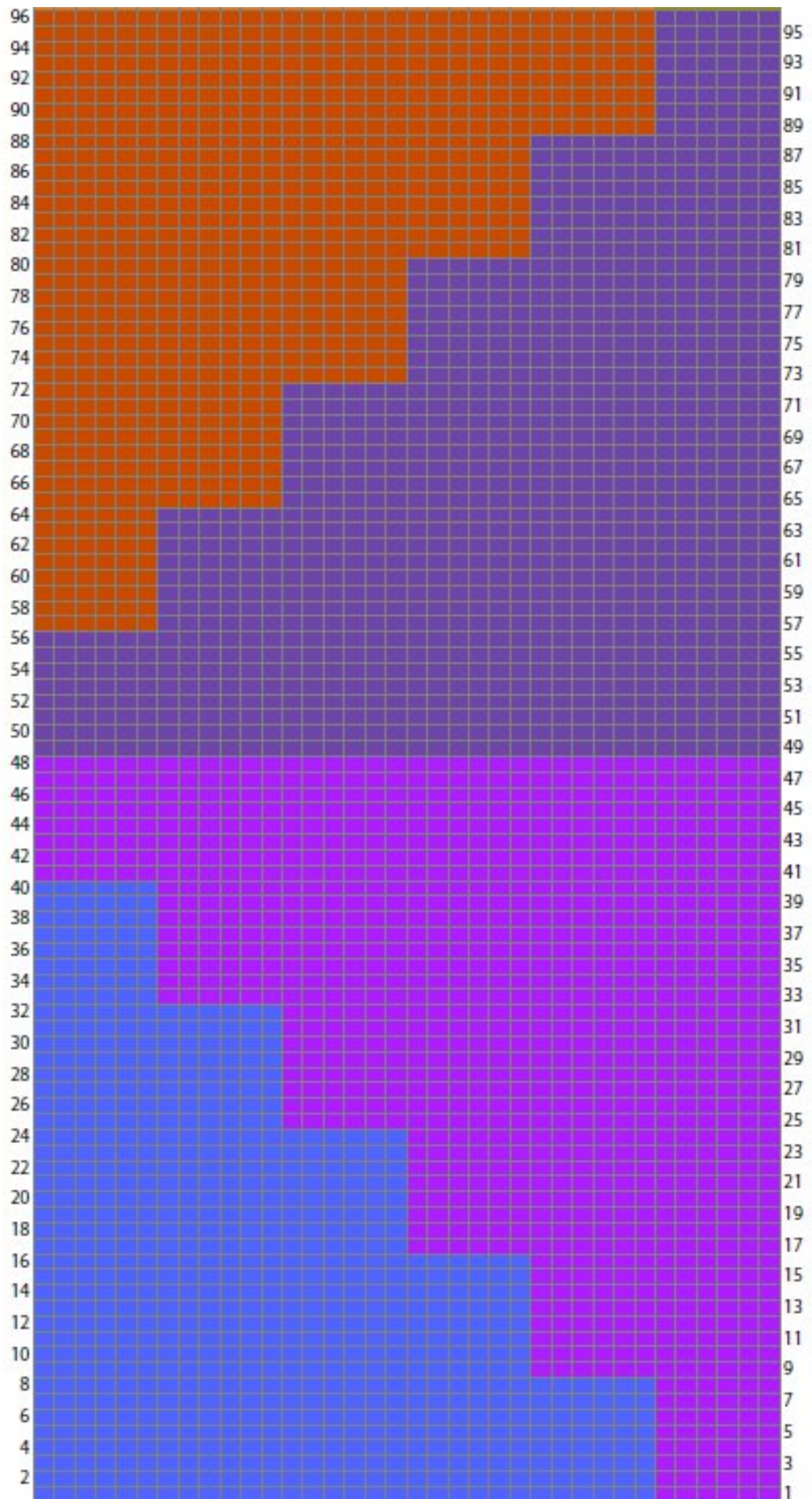

Sweaters & Cardigan

Cozy Textured Pullover

By: Lion Brand Design Team



Sizes XS/S (M/L, 1/2X);

Finished Chest 36 (44, 53) in. (91.5 (112, 134.5) cm)

Finished Length 28 (28 1/2, 29 1/2) in. (71 (72.5, 75) cm)

Note: Pattern is written for smallest size with changes for larger sizes in parentheses. When only one number is given, it applies to all sizes. To follow pattern more easily, circle all numbers pertaining to your size before beginning.

Materials:

- LION BRAND HOMESPUN THICK & QUICK (Art. #792)
 - #381 Barley 3 (4, 4) skeins
 - or color of your choice
- LION BRAND knitting needles size 13 (9 mm)
- LION BRAND knitting needles size 15 (10 mm)
- LION BRAND cable needle
- LION BRAND stitch markers
- LION BRAND large-eyed blunt needle
- Matching smooth yarn for sewing, if desired

Gauge: 9 1/2 sts = 5 in. (12.5 cm) + 10 rows = 4 in. (10 cm) in St st (k on RS, p on WS) with larger needles.
12 sts = about 5 in. (12.5 cm) in Center Cable pattern. BE SURE TO CHECK YOUR GAUGE.

When you match the gauge in a pattern, your project will be the size specified in the pattern and the materials specified in the pattern will be sufficient. If it takes you fewer stitches and rows to match the gauge, try using a smaller size hook or needles; if more stitches and rows, try a larger size hook or needles.

Notes

1. Pullover is worked in 4 pieces: Back, Front and 2 Sleeves.
2. When you see 'as established' in the instructions, this means to continue in the current pattern st.

Abbreviations

beg = begin(ning)(s)

k = knit

k2tog = knit 2 together

p = purl

p2tog = purl 2 together

rem = remain(ing)(s)

rep = repeat

RS = right side

st(s) = stitch(es)

St st = Stockinette st

WS = wrong side

STITCH EXPLANATIONS

5/5 LC (5 over 5 left cross) Slip 5 sts to cable needle and hold in front, k5, then k5 from cable needle.

kfb (knit in front and back) Knit next st without removing it from left needle, then k through back of same st – 1 st increased.

M1P (make 1 st as if to purl) An increase worked by lifting the horizontal strand lying between the needles and placing it onto the left needle. Purl this new stitch through the back loop – 1 st increased.

PATTERN STITCH

K1, p1 Rib (worked over an odd number of sts)

Row 1 (RS): K1, *p1, k1; rep from * to end of row.

Row 2: K the knit sts and p the purl sts.

Rep Row 2 for K1, p1 Rib.

BACK

With smaller needles, cast on 33 (41, 49) sts.

Work in K1, p1 Rib until piece measures 3 in. (7.5 cm) from beginning, end with a RS row. **Note:** End with a RS row means that the last row you work should be a RS row.

Change to larger needles.

Increase Row (WS): P17 (21, 25), M1P, p16 (20, 24) – 34 (42, 50) sts at the end of this row.

Work in St st (k on RS, p on WS) until piece measures about 19 in. (48.5 cm) from beg, end with a WS row.

Shape Armholes

Row 1 (RS): Bind off 1 (2, 3) st(s), k to end of row – 33 (40, 47) sts at the end of this row.

Row 2: Bind off 1 (2, 3) sts, p to end of row – 32 (38, 44) sts at the end of this row.

Rows 3 and 4: Rep last 2 rows once more – 30 (34, 38) sts at the end of Row 4.

Work even in St st until armholes measure 7 1/2 (8, 9) in. (19 (20.5, 23) cm), end with a WS row.

Shape Shoulders

Row 1 (RS): Bind off 5 (6, 7) sts, k to end of row – 25 (28, 31) sts.

Row 2: Bind off 5 (6, 7) sts, p to end of row – 20 (22, 24) sts.

Rows 3 and 4: Rep last 2 rows once more – 10 sts at the end of Row 4.

Bind off.

FRONT

With smaller needles, cast on 33 (41, 49) sts.

Work in K1, p1 Rib until piece measures 3 in. (7.5 cm) from beginning, end with a WS row.

Beg Center Cable Pattern

Change to larger needles.

Set-Up Row (RS): K5 (7, 9), kfb, k5 (7, 9), place marker (pm), M1P, k10, M1P, pm, k12 (16, 20) – 36 (44, 52) sts at the end of this row.

Row 1 (WS): P to marker, slip marker (sm), k1, p10, k1, sm, p to end of row.

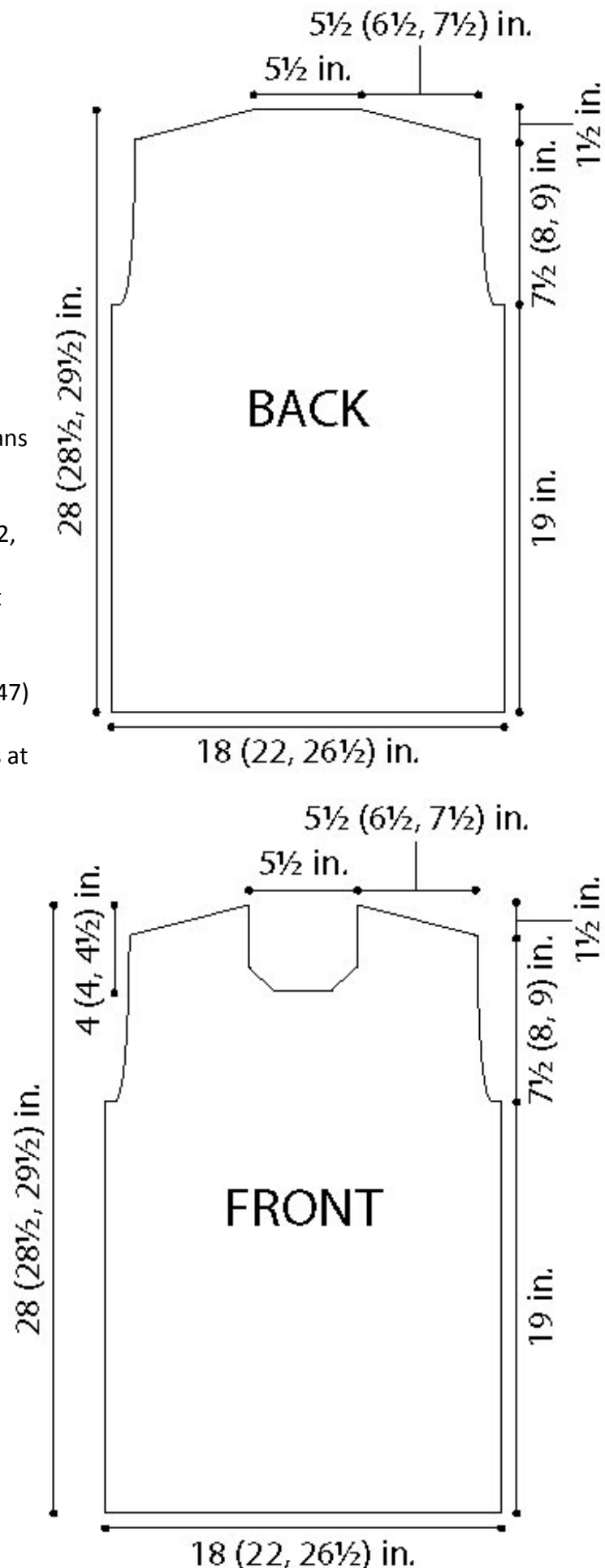

Row 2: K to marker, sm, p1, k10, p1, sm, k to end of row.

Row 3: P to marker, sm, k1, p10, k1, sm, p to end of row.

Rows 4 and 5: Rep Rows 2 and 3.

Row 6 (Cable Row): K to marker, sm, p1, 5/5 LC, p1, sm, k to end of row.

Row 7: Rep Row 3.

Rows 8-19: Rep Rows 2 and 3.

Row 20 (Cable Row): Rep Row 6.

Rep Rows 7-20 until piece measures 19 in. (48.5 cm) from beg, end with a WS row.

Shape Armholes

Row 1: Bind off 1 (2, 3) sts, work in pattern as established to end of row – 35 (42, 49) sts.

Row 2: Bind off 1 (2, 3) sts, work in pattern as established to end of row – 34 (40, 46) sts.

Rows 3 and 4: Rep last 2 rows once more – 32 (36, 40) sts at the end of this row.

Work even in pattern as established until armholes measure 5 (5 1/2, 6) in. (12.5 (14, 15) cm), end with a WS row.

Shape Neck

Row 1 (RS): K13 (15, 17) sts, join a 2nd ball of yarn and bind off next 6 sts for front neck, k to end of row – 13 (15, 17) sts on each side.

Work both sides at the same time using separate balls of yarn.

Row 2: On first side: P to last 3 sts, p2tog, p1; on 2nd side: p1, p2tog, p to end – 12 (14, 16) sts on each side.

Row 3: On first side: K to last 3 sts, k2tog, k1; on 2nd side: K1, k2tog, k to end – 11 (13, 15) sts on each side.

Row 4: Rep Row 2 – 10 (12, 14) sts on each side.

Work even in St st with separate balls of yarn until piece measures same as Back to shoulder shaping, end with a WS row.

Shape Shoulders

Row 1 (RS): On first side: Bind off 5 (6, 7) sts, k to end of side; on 2nd side: k to end of side.

Row 2: On first side: Bind off 5 (6, 7) sts, p to end of side; on 2nd side: p to end of side – 5 (6, 7) sts on each side.

Row 3: Bind off all sts on first side; k to end of 2nd side.

Row 4: Bind off all sts on rem side.

SLEEVES (make 2)

With smaller needles, cast on 13 (15, 17) sts.

Work in K1, p1 Rib until piece measures 4 in. (10 cm) from beg, end with a WS row.

Change to larger needles.

Increase Row (RS): (K3, kfb) 3 times, k to end of row – 16 (18, 20) sts.

Work even in St st for 7 rows.

Next Row (Increase): K1, kfb, k to last 2 sts, kfb, k1 – 18 (20, 22) sts.

Rep last 8 rows 3 (4, 5) more times – 24 (28, 32) sts when all increases have been completed.

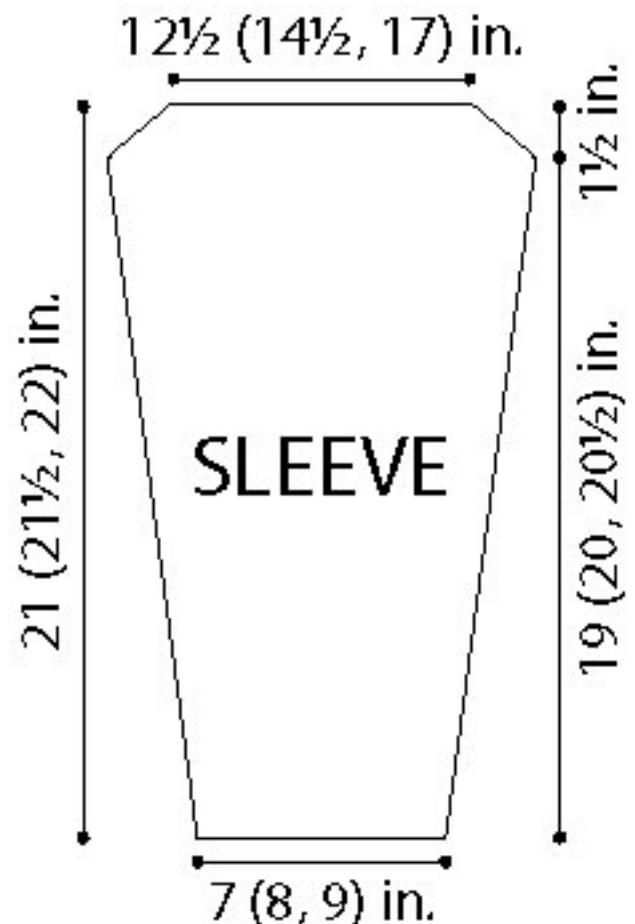

Work even in St st until piece measures 19 (20, 20 1/2) in. (48.5 (51, 52) cm) from beg, end with a WS row.

Shape Cap

Row 1 (RS): Bind off 2 sts, k to end of row – 20 (26, 30) sts at the end of this row.

Row 2: Bind off 2 sts, p to end of row – 20 (24, 28) sts at the end of this row.

Rows 3 and 4: Rep last 2 rows – 16 (20, 24) sts at the end of Row 4.

Bind off.

FINISHING

Note: Use smooth yarn for sewing, if desired.

Sew left shoulder seam.

Neckband

From RS with smaller needles, pick up and k31 (31, 33) sts evenly spaced around neck edge.

Work in K1, p1 Rib for 2 in. (5 cm).

Sew right shoulder seam including neckband. Sew in Sleeves. Sew side and Sleeve seams.

Weave in ends.

Every effort has been made to produce accurate and complete instructions. We cannot be responsible for variance of individual knitters or crocheters, human error, or typographical mistakes.

©2013 Lion Brand Yarn Company, all rights reserved.



**Homespun[®]
Thick & Quick[®]**
the super bulky version
of our fan-favorite,
American-made yarn,
available in over
20 colorways.



Discover inspiration, how-tos, and thousands of free patterns at LionBrand.com.

LionBrand.com

Cozy Hooded Poncho

By: Lion Brand Design Team



Sizes: S (M, L, 1X-2X)

Finished Circumference at Bust 44 (48, 52, 56) in. (112 (122, 132, 142) cm)

Note: Pattern is written for smallest size with changes for larger sizes in parentheses. When only one number is given, it applies to all sizes. To follow pattern more easily, circle all numbers pertaining to your size before beginning.

Materials:

- LION BRAND HEARTLAND (Art. #136)
 - #122 Grand Canyon 3 (3, 4, 4) balls (A)
 - or color of your choice
 - LION BRAND ROMANCE (Art. #325)
 - #098 Antique Lace 2 (3, 4, 4) balls (B)
 - or color of your choice
- LION BRAND stitch markers
- LION BRAND® cable needle
- LION BRAND® large-eyed blunt needle
- Circular knitting needle size 8 (5 mm), 24 in. (61 cm) long

Gauges: 20 sts + 22 rows = 4 in. (10 cm) in Cable Pattern with A.

15 sts + 22 rnds = 4 in. (10 cm) in Rev St st worked in the rnd (p every rnd) with A.

12 sts + 24 rnds = 4 in. (10 cm) in Rev St st worked in the rnd with B.

BE SURE TO CHECK YOUR GAUGE.

When you match the gauge in a pattern, your project will be the size specified in the pattern and the materials specified in the pattern will be sufficient. If it takes you fewer stitches and rows to match the gauge, try using a smaller size hook or needles; if more stitches and rows, try a larger size hook or needles.

Abbreviations

beg = begin(ning)
dec = decreas(e)(s)(ing)
inc = increas(e)(s)(ing)
k = knit
k2tog = knit 2 together
pm = place marker
p = purl
p2tog = purl 2 together
rem = remain(ing)

rep = repeat
Rev St st = Reverse Stockinette stitch
RS = right side
rnd(s) = round(s)
sm = slip marker
st(s) = stitch(es)
St st = Stockinette stitch
WS = wrong side

Stitch Explanations

3/3 LC (3 over 3 left cross) Slip 3 sts to cable needle and hold in front, k3, then k3 from cable needle.

3/3 RC (3 over 3 right cross) Slip 3 sts to cable needle and hold in back, k3 then k3 from cable needle.

kfb (knit in front and back) Knit next st without removing it from left needle, then k through back of same st – 1 st increased.

Pattern Explanations

Cable Pattern I (worked in rows over 9 sts)

Row 1: Knit.

Rows 2, 4 and 6: Purl

Row 3: 3/3 RC, k3.

Row 5: Knit.

Row 7: K3, 3/3 LC.

Row 8: Purl

Rep Rows 1-8 for Cable patt I.

Cable Pattern II (worked in the rnd over 9 sts)

Rnds 1 and 2: Knit.

Rnd 3: 3/3 RC, k3.

Rnds 4, 5 and 6: Knit.

Rnd 7: K3, 3/3 LC.

Rnd 8: Knit.

Rep Rows 1-8 for Cable patt II.

NOTES

1. The Lower Band is worked as a flat strip, working back and forth in rows on the circular needle. Ends of strip are seamed to make a ring, then sts are picked up along one long edge of the Band for the Poncho.
2. A cable pattern is worked on the Lower Band, Poncho, front band and hood. If desired, stitch markers can be used to highlight those sts.
3. Poncho is worked in the round, then divided at neck and worked back and forth in rows.
4. After shaping at top of Poncho has been completed, the remaining sts are used to make the front band.
5. Sts are picked up along the edge of the front band to make the hood.
6. Some sections of the Poncho include selvedge sts. These are sts that create an edge for seaming pieces together.

PONCHO

Lower Band

Note: Lower Band is worked back and forth on a circular needle in rows, as if working on straight needles.

With A, cast on 15 sts.

Row 1: K2, p1, work Row 1 of Cable patt I over next 9 sts, p1, k2.

Row 2: K1, p1, k1, work next row of Cable patt I to next marker, k1, p1, k1.

Row 3: K2, p1, work next row of Cable patt I to next marker, p1, k2.

Rep Rows 2 and 3 until piece measures about 44 (48, 52, 56) in. (112 (122, 132, 142) cm) from beg.

Bind off.

Seam cast on end of Band to bound off end of Band to make a ring.

Discover inspiration, how-tos, and thousands of free patterns at LionBrand.com.



Romance

a luxuriously soft
eyelash yarn in fashion
forward brights and
rich natural shades.



LionBrand.com

Poncho

Along one long edge of Band, measure about 11 (12, 13, 14) in. (28 (30.5, 33, 35.5) cm) from seam and place a marker.

Note: To work the next section, you will be picking up sts evenly spaced across the marked edge of Band. An easy way to do this is to divide the edge into halves, then quarters, etc - using pins or scraps of yarn to mark the sections. Now, simply pick up and k sts within each of the sections - for example, for the smallest size you will need to pick up and k 132 sts. If you first divide the long edge of the Band into 8 equal size sections, you should pick up and k 16 sts evenly spaced across sections 1, 3, 5 and 7 and 17 sts evenly spaced across sections 2, 4, 6 and 8 for a total of 132 sts.

From RS with B and beg at marker, pick up and k132 (144, 156, 168) sts evenly spaced along long, marked edge of Band. Place marker for beg of rnd. Join by working the first st on left hand needle with the working yarn from the right hand needle and being careful not to twist sts.

Work in Rev St st worked in the rnd (p every rnd) for 7 rnds.

Change to A.

Next Rnd: With A, k11 (12, 13, 14), *kfb, k1; rep to last 11 (12, 13, 14) sts, kfb, k to end of rnd – 187 (204, 221, 238) sts at the end of this rnd.

Next Rnd: *Work Rnd 1 of Cable patt II over 9 sts, p8; rep from * around.

Next Rnd: *Work next rnd of Cable patt II over 9 sts, p8; rep from * around.

Rep last rnd until piece measures about 12 (12 1/2, 13, 13 1/2) in. (30.5 (32, 33, 34.5) cm) from pick up rnd, ending with a Rnd 4 or Rnd 8.

Note: Ending with a Rnd 4 or Rnd 8 means that the last rnd you work should be a Rnd 4 or Rnd 8.

Divide for Neck

Note: The remainder of Poncho will be worked back and forth in rows on circular needle. If you ended with a Rnd 4 above, you should beg Next Row with Row 5 of Cable patt I. If you ended with a Rnd 8 above, beg Next Row with Row 1 of Cable patt I.

Next Row (RS): K1 (selvedge st for neck), kfb, k7, *p8, work next row of Cable patt I over next 9 sts; rep from * to last 8 sts, p6, kfb, k1 (selvedge st for neck) –189 (206, 223, 241) sts. Remove beg of rnd marker.

Next Row (WS): K1 (selvedge st), pm, k8 (Rev St st worked in rows), work next row of Cable patt I over next 9 sts, pm, * k8 (Rev St st worked in rows), work next row of Cable patt I over next 9 sts; rep from * to last st, k1 (selvedge st).

Decrease for top of Poncho

Next (Dec) Row (RS): K1, *work next row of Cable patt I over next 9 sts, p2tog, p6; rep from * to last st, k1 – 178 (194, 210, 227) sts.

Keeping first and last sts in Garter st (k every row), remaining sts in Cable patt I and Rev St st st, work even for 3 rows.

Note: When you see 'work even' in the instructions, this means to continue on in the pattern st you have established without changing the st count by increasing, decreasing, or binding off.

Next (Dec) Row: K1, *work next row of Cable patt I over next 9 sts, p2tog, p5; rep from * to last st, k1 –167 (182, 197, 213) sts.

Work even for 3 rows.

Next (Dec) Row: K1, *work next row of Cable patt I over next 9 sts, p2tog, p4; rep from * to last st, k1 –156 (170, 184, 199) sts.

Work even for 3 rows.

Next (Dec) Row: K1, *work next row of Cable patt I over next 9 sts, p2tog, p3; rep from * to last st, k1 –145 (158, 171, 185) sts.

Work even for 3 rows.

Next (Dec) Row: K1, *work next row of Cable patt I over next 9 sts, p2tog, p2; rep from * to last st, k1 –134 (146, 158, 171) sts.

Work even for 3 rows.

Next (Dec) Row: K1, *work next row of Cable patt I over next 9 sts, p2tog, p1; rep from * to last st, k1 –123 (134, 145, 157) sts.

Work even for 3 rows.

Next (Dec) Row: K1, *work next row of Cable patt I over next 9 sts, p2tog; rep from * to last st, k1 –112 (122, 132, 143) sts.

Work even for 3 rows.

Next (Dec) Row: K1, *work 8 sts in Cable patt I, k2tog; rep from * to last st, k1 – 101 (110, 119, 129) st.

Size S ONLY

Proceed to All Sizes, below.

Sizes M (L, 1X/2X) ONLY

Next Row (WS): P1 (1, 13), *p2tog, p8 (4, 2); rep from * to last 3 (3, 13) sts, p2tog, p to end of row – 101 sts.

Next Row: Knit.

All Sizes

Next Row (WS): Bind off 90 sts for neck, k1, work next row of Cable patt I over next 9 sts, k1 – 11 sts.

Front Band for Hood

Note: Front band is worked on rem 11 sts then sewed to the left neck edge. Sts are then picked up along the band to make the hood.

Next Row: K1, work next row of Cable patt I over next 9 sts, k1.

Rep last row until piece measures about 34 1/2 in. (87.5 cm) from picked up sts, end with a WS row.

Note: End with a WS row means that the last row that you work should be a WS row.

Bind off.

Without twisting band, sew edge of last 5 1/2 (6, 6, 6) in. (14 (15, 15, 15) cm) of band to neck, refer to schematic to match A to A and B to B. Sew bound off end of band to inside of Poncho.

Hood

Note: Hood is worked back and forth in rows.

From RS with B, pick up and k 86 sts evenly spaced along inner edge of front band.

Work in Rev St st for 7 rows.

Change to A.

Next (Inc) Row (RS): K6, *k1, kfb; rep from * to last 6 sts, k6 – 123 sts.

Next Row: K1, *work Row 2 of Cable patt I over next 9 sts, k5; rep from * to last 10 sts, work Row 2 of Cable patt I over next 9 sts, k1.

Next Row (RS): K1, *work next row of Cable patt I over next 9 sts, p5; rep from * to last 10 sts, work next row of Cable patt I over next 9 sts, k1.

Next Row (WS): K1, *work next row of Cable patt I over next 9 sts, k5; rep from * to last 10 sts, work next row of Cable patt I over next 9 sts, k1.
Rep last 2 rows until piece measures about 8 in. (20.5 cm) from picked up sts, ending with a WS Row.

Shape Hood

Next Row (RS): Bind off 42 sts (for side of hood), *work next row of Cable patt I over next 9 sts, p5; rep from * to last 10 sts, work next row of Cable patt I over next 9 sts, k1 – 81 sts.

Next Row (WS): Bind off 42 sts (for side of hood), *work next row of Cable patt I over next 9 sts, k5; rep from * to last 10 sts, work next row of Cable patt I over next 9 sts, k1 – 39 sts rem.

Note: You will now continue on remaining sts for center panel of hood.

Next Row: K1 (selvedge st), *work next row of Cable patt I over next 9 sts, p5; rep from * to last 10 sts, work next row of Cable patt I over next 9 sts, k1 (selvedge st).

Next Row: K1, *work next row of Cable patt I over next 9 sts, k5; rep from * to last 10 sts, work next row of Cable patt I over next 9 sts, k1.

Rep last 2 rows until piece measures about 7 1/2 in. (19 cm) from bound off sts.
Bind off.

FINISHING

Sew bound off edge of sides of hood to center panel of hood. Sew lower edge of hood to Poncho neck.
Weave in ends.

Every effort has been made to produce accurate and complete instructions. We cannot be responsible for variance of individual knitters or crocheters, human error, or typographical mistakes.

©2013 Lion Brand Yarn Company, all rights reserved.

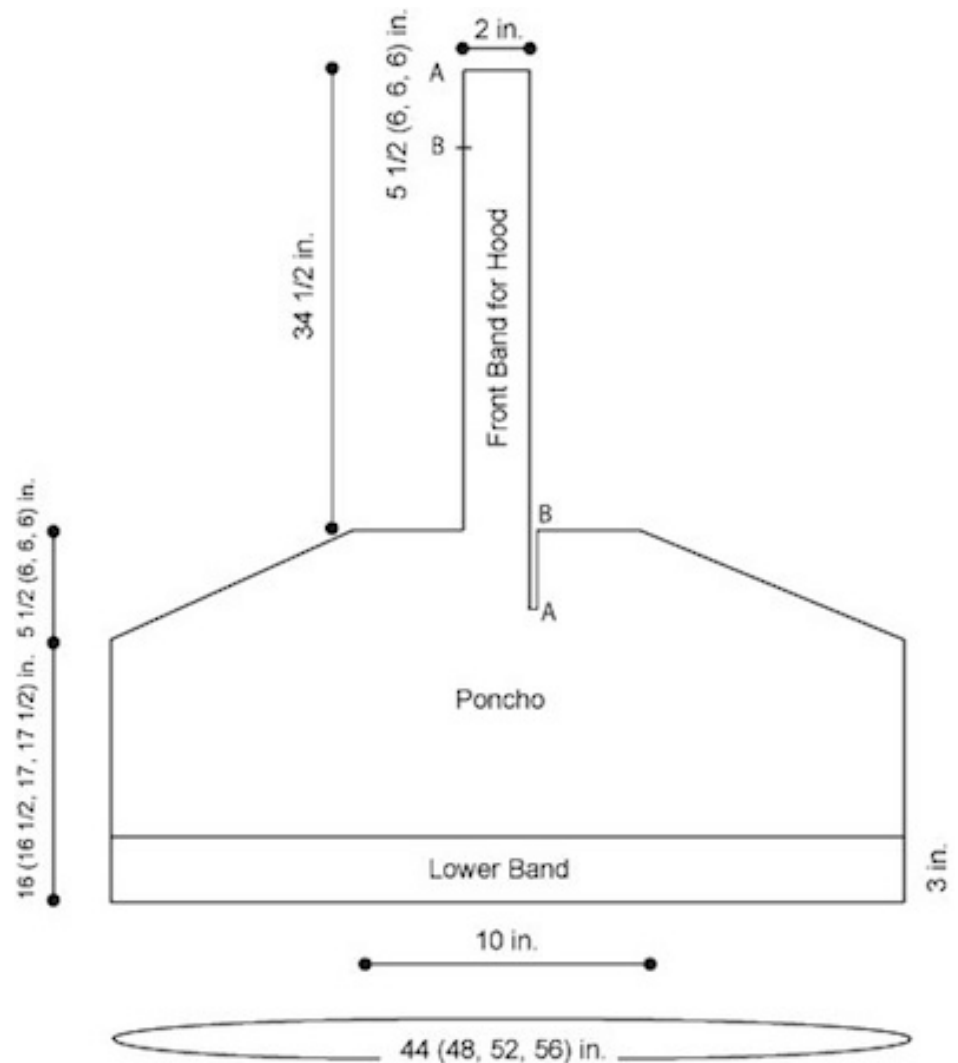

Easy Color Hoodie

By: Lion Brand Design Team



Sizes: 1-2 years (3-4 years, 5-7 years, 8-10 years)

Finished Chest 23 1/2 (25, 28, 31) in. (59.5 (63.5, 71, 78.5) cm)

Finished Length (from back neck) 11 1/2 (13 1/2, 15 1/2, 16 1/2) in. (29 (34.5, 39.5, 42) cm)

Note: Pattern is written for smallest size with changes for larger sizes in parentheses. When only one number is given, it applies to all sizes. To follow pattern more easily, circle all numbers pertaining to your size before beginning.

Materials:

- LION BRAND UNIQUE (Art. #755)
 - #205 Grapevine 3 (4, 5, 6) balls
 - or color of your choice
- LION BRAND knitting needles size 9 (5.5 mm)
- LION BRAND stitch markers
- LION BRAND stitch holder
- LION BRAND large-eyed blunt needle
- 2 buttons, about 3/4 in. (19 mm) diameter

Gauge: 13 sts + 20 rows = about 4 in. (10 cm) in Zigzag pattern. BE SURE TO CHECK YOUR GAUGE.

When you match the gauge in a pattern, your project will be the size specified in the pattern and the materials specified in the pattern will be sufficient. If it takes you fewer stitches and rows to match the gauge, try using a smaller size hook or needles; if more stitches and rows, try a larger size hook or needles.

Abbreviations

beg = begin(ning)(s)

k = knit

k2tog = knit 2 together

p = purl

rem = remain(ing)(s)

rep = repeat

RS = right side

St st = Stockinette st

st(s) = stitch(es)

WS = wrong side

yo = yarn over

Stitch Explanations

1/1 LC (1 over 1 left cross) Slip 1 st to cable needle and hold in front of work, k1, then k1 from cable needle.

1/1 RC (1 over 1 right cross) Slip 1 st to cable needle and hold in back of work, k1, then k1 from cable needle.

M1 (make 1) An increase worked by lifting the horizontal strand lying between needles and placing it onto the left needle. Knit this new stitch through the back loop – 1 st increased.

sl2kp (slip 2-k1-pass slipped sts over)

Discover inspiration, how-tos, and thousands of free patterns at LionBrand.com.

Get inspiration,
special offers,
and more from

Lion Brand



facebook.com/LionBrandYarns



[@LionBrandYarn](https://twitter.com/LionBrandYarn)



pinterest.com/LionBrandYarn



youtube.com/LionBrandYarn



LionBrand.com

A double decrease worked as follows:

1. Insert right needle into next 2 sts as if to knit them tog, and slip them from the left needle to the right needle.
2. Knit the next st.
3. With tip of left needle, lift the 2 slipped sts (the 2nd and 3rd sts on the right needle) up and over the knit st (first st on right needle) and off the needle – you have decreased 2 sts.

Pattern Stitch

Zigzag Pattern (worked over a multiple of 5 sts + an additional st)

Row 1 (RS): K1, *1/1 LC, k3; rep from * to end of row.

Row 2: K3, p1, *k4, p1; rep from * to last 2 sts, k2.

Row 3: K2, 1/1 LC, *k3, 1/1 LC; rep from * to last 2 sts, k2.

Row 4: K2, p1, *k4, p1; rep from * to last 3 sts, k3.

Row 5: K3, 1/1 LC, *k3, 1/1 LC; rep from * to last st, k1.

Row 6: K1, p1, *k4, p1; rep from * to last 4 sts, k4.

Row 7: *K3, 1/1 RC; rep from * to last st, k1.

Row 8: Rep Row 4.

Row 9: K2, 1/1 RC, *k3, 1/1 RC; rep from * to last 2 sts, k2.

Row 10: Rep Row 2.

Row 11: K1, 1/1 RC, *k3, 1/1 RC; rep from * to last 3 sts, k3.

Row 12: *K4, p1; rep from * to last st, k1.

Rep Rows 1-12 for Zigzag pattern.

Notes

1. Hoodie is worked in one piece beg at lower edge. Piece is divided at armhole, then fronts and back are worked separately.
2. Lower section of body is worked in Zigzag pattern.
3. Sleeves are worked separately with Zigzag pattern at lower edge.
4. Hood is worked by picking up sts around the neck edge.

HOODIE

Cast on 76 (81, 91, 101) sts.

Knit 1 row.

Beg with Row 1 (RS) of pattern, work in Zigzag pattern for 36 (36, 50, 50) rows.

Beg with a RS (knit) row, work in St st (k on RS, p on WS) for 1 (7, 1, 1) row(s).

Left Front

Dividing Row (WS): K3 for Garter st front band, p17 (19, 21, 24) for left front, place rem 56 (59, 67, 74) sts on holder for back and right front.

Row 1: Working on 20 (22, 24, 27) sts for left front only, knit.

Row 2: K3, p to end of row.

Rows 3-14 (16, 20, 24): Rep last 2 rows 6 (7, 9, 11) more times.

Row 15 (17, 21, 25): Knit.

Shape Neck

Row 1 (WS): Bind off 6 (7, 8, 9) sts, p to end of row – 14 (15, 16, 18) sts.

Rows 2 and 4: Knit.

Row 3: Bind off 3 sts, p to end of row – 11 (12, 13, 15) sts.

Row 5: Bind off 1 (2, 2, 2) st(s), p to end of row – 10 (10, 11, 13) sts.

Bind off.

Back

Dividing Row (WS): P36 (37, 43, 47) sts from holder, leave last 20 (22, 24, 27) sts on holder for right front.

Work in St st on 36 (37, 43, 47) sts of back for 20 (22, 26, 30) rows.

Bind off.

Right Front

Dividing Row (WS): Working across rem sts on holder, p17 (19, 21, 24), k3.

Row 1 (RS): Knit.

Row 2: P to last 3 sts, k3.

Rows 3 and 4: Rep Rows 1 and 2.

Row 5 (Buttonhole Row): K1, yo, k2tog, k to end of row.

Row 6: P to last 3 sts, k3.

Row 7: Knit.

Rows 8-11 (13, 17, 21): Rep last 2 rows 2 (3, 5, 7) more times.

Row 12 (14, 18, 22): P to last 3 sts, k3.

Row 13 (15, 19, 23): Rep Row 5 (Buttonhole Row).

Row 14 (16, 20, 24): P to last 3 sts, k3.

Shape Neck

Row 1 (RS): Bind off 6 (7, 8, 9) sts, k to end of row – 14 (15, 16, 18) sts.

Rows 2 and 4: Purl.

Row 3: Bind off 3 sts, k to end of row – 11 (12, 13, 15) sts.

Row 5: Bind off 1 (2, 2, 2) st(s), k to end of row – 10 (10, 11, 13) sts.

Row 6: Purl.

Bind off.

SLEEVES (make 2)

Cast on 23 (23, 28, 28) sts.

Knit 1 row.

Zigzag Section

Row 1 (RS): K1, place marker (pm), work Row 1 of Zigzag pattern over next 21 (21, 26, 26) sts, pm, k1.

Rows 2-10: K1, slip marker (sm), work next row of Zigzag pattern to next marker, sm, k1.

Row 11 (Increase): K1, M1, sm, work next row of Zigzag pattern to next marker, sm, M1, k1 – 25 (25, 30, 30) sts at the end of this row.

Rows 12-16: K to marker, sm, work next row of Zigzag pattern to next marker, sm, k to end of row.

Row 17 (Increase): K1, M1, k to marker, sm, work next row of Zigzag pattern to next marker, sm, k to last st, M1, k1 – 27 (27, 32, 32) sts.

Rows 18-23: Rep Rows 12-17 – 29 (29, 34, 34) sts.

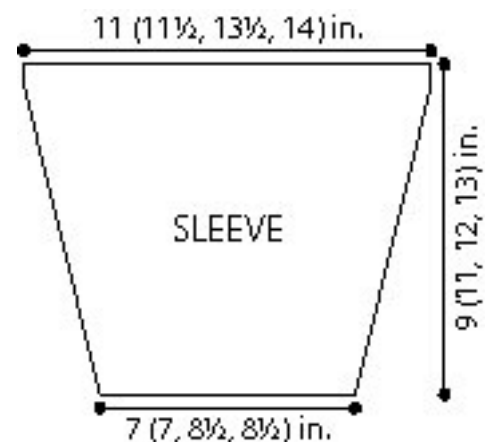

Row 24: K to marker, remove marker, work next row of Zigzag pattern to next marker, remove marker, k to end of row.

St st Section

Work in St st for 4 rows.

Increase Row: K1, M1, k to last st, M1, k1 – 31 (31, 36, 36) sts.

Work in St st for 5 rows.

Rep Increase Row – 33 (33, 38, 38) sts.

Rep last 6 rows 1 (2, 3, 4) more time(s) – 35 (37, 44, 46) sts.

Work even in St st until piece measures about 9 (11, 12, 13) in. (23 (28 (30.5, 33) cm) from beg, end with a WS row as your last row.

Bind off.

FINISHING

Sew shoulder seams.

Hood

Row 1 (RS): From RS, pick up and k14 (16, 17, 18) sts evenly spaced along right front neck edge, 17 (19, 21, 23) sts evenly spaced along back neck, 14 (16, 17, 18) sts evenly spaced along left front neck edge – 45 (51, 55, 59) sts at the end of this row.

Row 2: K6, pm, p to last 6 sts, pm, k6.

Row 3: Work Row 1 of Zigzag pattern to marker, sm, k to next marker, sm, work Row 1 of Zigzag pattern to end of row.

Row 4: Work next row of Zigzag pattern to marker, sm, p to next marker, sm, work same row of Zigzag pattern to end of row.

Row 5 (Increase): Work next row of Zigzag pattern to marker, sm, k2 (2, 2, 1), M1, [k6 (7, 8, 9), M1] 5 times, k1 (2, 1, 1), sm, work in Zigzag pattern to end of row – 51 (57, 61, 65) sts at the end of this row.

Row 6: Work next row of Zigzag pattern to marker, sm, p to next marker, sm, work in Zigzag pattern to end of row.

Row 7: Work next row of Zigzag pattern to marker, sm, k to next marker, sm, work in Zigzag pattern to end of row.

Rep last 2 rows until piece measures about 7 (8, 8 1/2, 9 1/2) in. (18 (20.5, 21.5, 24) cm) from beg, end with a WS row.

Shape Top of Hood

Row 1 (RS – Decrease): Work next row of Zigzag pattern to marker, sm, k18 (21, 23, 25), sl2kp, k1, pm, k17 (20, 22, 24), sm, work in Zigzag pattern to end of row – 49 (55, 59, 63) sts.

Rows 2 and 4: Work next row of Zigzag pattern to marker, sm, p to next marker, sm, work in Zigzag pattern to end of row.

Row 3: Work next row of Zigzag pattern to marker, sm, k to next marker, sm, work in Zigzag pattern to end of row.

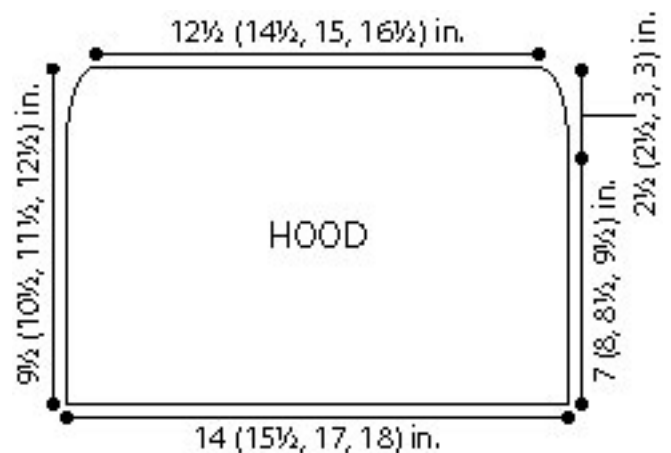

Row 5 (Decrease): Work next row of Zigzag pattern to marker, sm, k to 3 sts before next marker, sl2kp, remove marker, k1, pm, k to next marker, sm, work in Zigzag pattern to end of row – 47 (53, 57, 61) sts.

Row 6: Rep Row 2.

Rep last 2 rows 3 (3, 4, 4) more times – 41 (47, 49, 53) sts when all decreases have been completed.

Bind off. Fold last row in half and sew edges together for top of Hood.

Sew Sleeve seams. Sew

Sleeves into armholes.

Sew buttons to left front, opposite buttonholes.

Weave in ends.

Every effort has been made to produce accurate and complete instructions. We cannot be responsible for variance of individual knitters or crocheters, human error, or typographical mistakes.

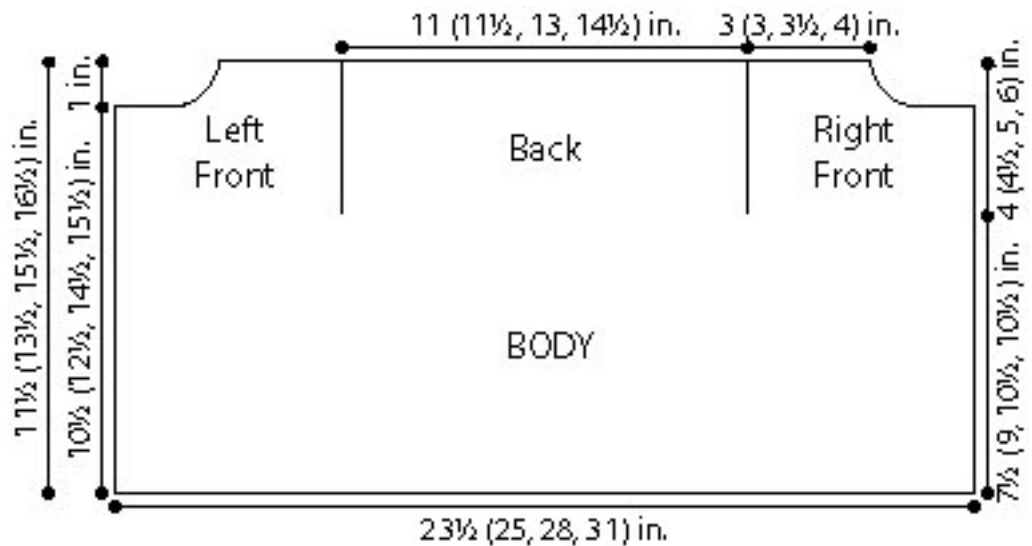

©2013 Lion Brand Yarn Company, all rights reserved.

Discover All of Lion Brand's Great Products



Download a free copy of Lion Design 2013-2014 here!

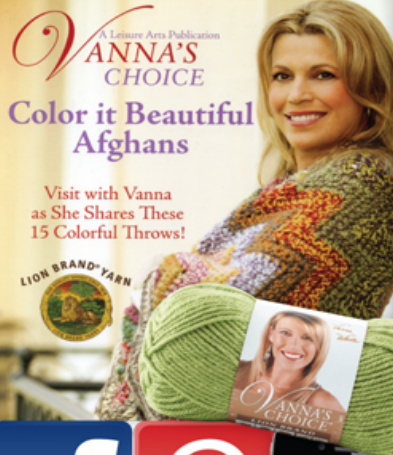

FOR 135 YEARS,
WE'VE BEEN WITH YOU
EVERY STITCH OF THE WAY.

We offer the most imaginative collection of quality yarns, 5,000 free patterns and know-how you can trust through an e-newsletter, podcasts, videos and more. We have inspired you since 1878 and look forward to more to come in the next 135 years.

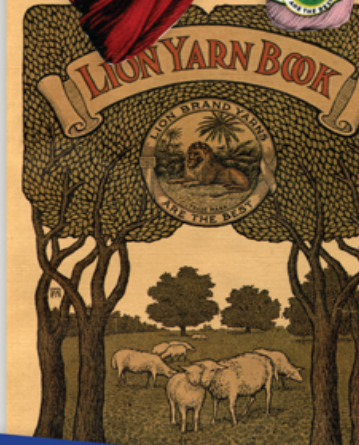

LionBrand.com

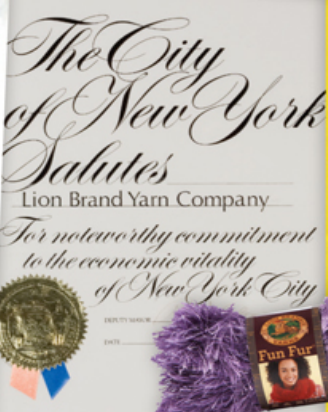

Chic Baby Cardigan

By: Lion Brand Design Team



Sizes: 1 (2, 3) years

Finished Chest 21 (23 1/2, 26) in. (53.5 (60, 66) cm), closed

Finished Length 12 (13, 14) in. (30.5 (33, 35.5) cm)

Note: Pattern is written for smallest size with changes for larger sizes in parentheses. When only one number is given, it applies to all sizes. To follow pattern more easily, circle all numbers pertaining to your size before beginning.

Materials:

- LION BRAND VANNA'S CHOICE (Art. #860)
 - #401 Grey Marble 2 (3, 3) balls (A)
 - #112 Raspberry 1 (1, 1) ball (B)
 - or colors of your choice
- LION BRAND knitting needles size 7 (4.5 mm)
- LION BRAND knitting needles size 9 (5.5 mm)
- LION BRAND stitch markers
- LION BRAND stitch holders
- LION BRAND large-eyed blunt needle
- 4 small snap fasteners
- Sewing needle and thread

Gauge: 16 sts + 22 rows = 4 in. (10 cm) in St st (k on RS, p on WS) with larger needles. BE SURE TO CHECK YOUR GAUGE.

When you match the gauge in a pattern, your project will be the size specified in the pattern and the materials specified in the pattern will be sufficient. If it takes you fewer stitches and rows to match the gauge, try using a smaller size hook or needles; if more stitches and rows, try a larger size hook or needles.

Abbreviations

beg = begin(ning)

k = knit

k2tog = knit 2 sts together

p = purl

p2tog = purl 2 sts together

rep = repeat

RS = right side

st(s) = stitch(es)

St st = Stockinette stitch

WS = wrong side

Stitch Explanations

Kfb (knit in front and back) Knit next st without removing it from the left needle, then k through the back of same st – 1 st increased

M1 (make 1) An increase worked by lifting the horizontal strand lying between needles and placing it onto left needle. Knit this new stitch through the back loop – 1 st increased.

Pattern Stitches

K1, p1 Rib (worked over a multiple of 2 sts + 1 additional st)

Row 1 (RS): K1, *p1, k1; rep from * to end of row.

Row 2: K the knit sts and p the purl sts.

Rep Row 2 for K1, p1 Rib.

Two Color Pattern (worked over a multiple of 2 sts)

Rows 1 and 3 (WS): With B, purl.

Row 2: *With B, k1, with A, k1; rep from * to end of row.

Rows 4 and 6: With A, knit.

Row 5: *With B, p1, with A, p1; rep from * to end of row.

Rows 7-9: Rep Rows 1-3.

Notes

1. Cardigan body is worked in one piece to armholes, then divided for back and fronts.
2. Two color pattern is worked in stranded colorwork. Carry unused color across WS of work.
3. Front bands are worked in one with the fronts.
4. Collar and sleeves are worked separately.

CARDIGAN

Body

With smaller needles and B, cast on 101 (109, 115) sts. Change to A and work in K1, p1 Rib for 1 in. (2.5 cm), end with a WS row as your last row.

Decrease Row (RS): Work in K1, p1 Rib as established over 5 sts, place marker (pm) *k5 (7, 13) k2tog; rep from * to last 5 sts, pm, work in K1, p1 rib over last 5 sts – 88 (98, 108) sts.

Change to larger needles.

Next Row (WS): Work in K1, p1 Rib to first marker, slip marker (sm), p to next marker, sm, work in K1, p1 Rib over last 5 sts.

Next Row: Work in K1, p1 Rib to first marker, sm, k to next marker, sm, work in K1, p1 Rib over last 5 sts.

Begin Two Color pattern

Row 1 (WS): With A, work in K1, p1 Rib to marker, sm, join B and work Row 1 of Two Color pattern to next marker, sm, with A, work in K1, p1 Rib over last 5 sts.

Row 2: With A, work in K1, p1 Rib to marker, sm, join B and work next row of Two Color pattern to next marker, sm, with A, work in K1, p1 Rib over last 5 sts.

Rows 3-9: Continue as established, working first and last 5 sts in K1,p1 Rib with A and remaining sts in Two Color pattern.

At the end of Row 9, fasten off B and continue with A only.

Next Row: With A, work in rib as established to marker, sm, work in St st (k on RS, p on WS) to next marker, sm, work in rib as established to end.

Continue as established, working first and last 5 sts in rib and remaining sts in St st until piece measures about 7 (7 1/2, 8) in. (18 (19, 20) cm) from beg, ending with a WS row as your last row.

Divide for Fronts and Back

Note: Fronts and back are worked with separate balls of yarn. For smallest size, wind A into 3 separate balls.

Discover inspiration, how-tos, and thousands of free patterns at LionBrand.com.

Sign up for our
FREE newsletter
the **WEEKLY STITCH**



get **inspiration**



check out **how-tos**



discover **great
pattern ideas**

Subscribe at
LionBrand.com!

Dividing Row: With A, work in rib as established to marker, sm, k17 (19, 21) for right front; join a 2nd ball of A and k44 (50, 56) sts for back; join a 3rd ball of A and k 17 (19, 21) for left front, sm, work in rib as established to end.

Continue as established, working fronts and back with separate balls of yarn and keeping first and last 5 sts in rib and remaining sts in St st until piece measures about 2 (2 1/2, 3) in. (5 (6.5, 7.5) cm) from Dividing Row, end with a WS row as your last row.

Shape Neck

Next Row (RS): Bind off 5 sts, remove marker, k to end of right front, across back and to last 5 sts of left front, sm, work in rib to end.

Next Row: Bind off 5 sts, remove marker, p to end of left front, across back and right front.

Next Row: Bind off 3 sts, working each piece with separate balls of yarn, k to end of row.

Next Row: Bind off 3 sts, working each piece with separate balls of yarn, p to end of row.

Next Row: Bind off 2 sts, working each piece with separate balls of yarn, k to end of row.

Next Row: Bind off 2 sts, working each piece with separate balls of yarn, p to end of row – 12 (14, 16) sts remain on each front.

Work even in St st, with separate balls of yarn until piece measures about 4 (4 1/2, 5) in. (10 (11.5, 12.5) cm) from Dividing Row, end with a RS row as your last row.

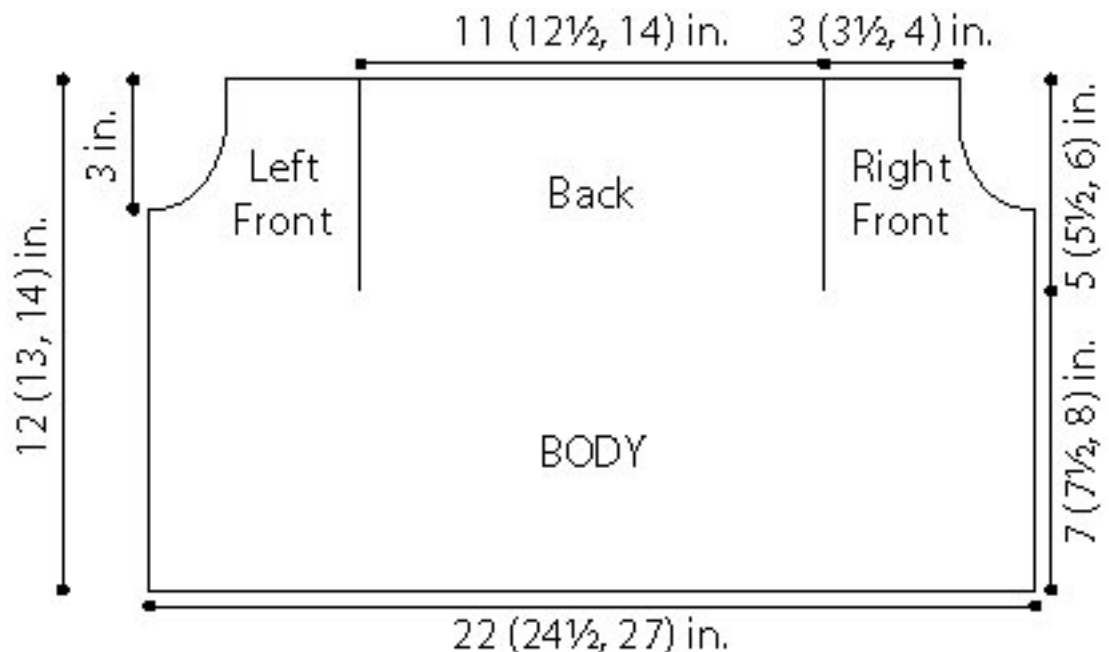

Two Color pattern, upper edge of left front

Beg with Row 1, work rows 1-6 of Two Color pattern across sts of left front, slip sts for back and for right front onto holders.

Next Row (WS): With A, knit.

With A, bind off all stitches.

Slip sts of back onto needle and work same as for upper edge of left front, then sl sts of right front back onto needle and work same as for upper edge of left front.

SLEEVES (make 2)

With smaller needles, and B cast on 29 (31, 33) sts. Change to A and work in K1, p1 Rib for 1 in. (2.5 cm), end with a RS row as your last row.

Next Row: Work in rib as established to last 2 sts, p2tog – 28 (30,32) sts. Change to larger needles.

Join B and work Rows 1-9 of Two Color pattern. At the end of Row 9, cut B.

Next Row (RS): With A, k1, m1, k to last st, m1, k1 – 30 (32, 34) sts.

Work 3 rows in St st.

Repeat last 4 rows 3 (5,7) more times – 36 (42, 48) sts.

Work even in St st until piece measures 6 1/2 (10, 11 1/2) in. (16.5 (25.5, 29 cm) from beg, end with a RS row as your last row.

Join B and work Rows 5-9 of Two Color pattern. At the end of Row 9, cut B.

Next Row (RS): With A, knit 1 row.

Bind off all sts.

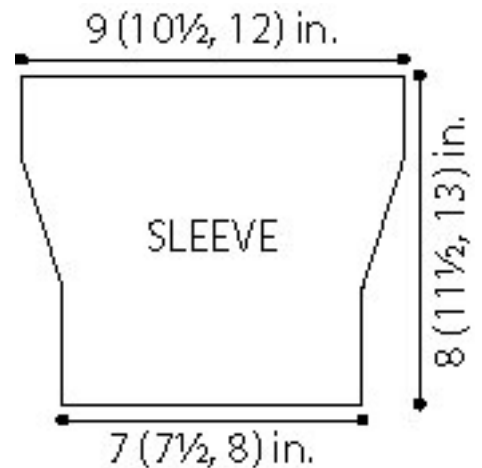

COLLAR

With smaller needles and B, cast on 60 (62, 64) sts.

Work in Garter st (k every row) for 6 rows.

Change to larger needles.

Next Row: Kfb in first st, k to end of row – 61 (63, 65) sts.

Rep last row 5 times – 66 (68, 70) sts. Change to A, cut B.

With A, bind off.

FINISHING

Sew shoulder seams. Sew sleeve seams and then sew Sleeves into armholes. Sew cast on edge of collar to neck edge.

With B and large-eyed blunt needle, work a vertical row of chain st along each line created by the purl sts in each front band.

With sewing needle and thread, sew snap fasteners evenly spaced along front edges.

Weave in ends.

Every effort has been made to produce accurate and complete instructions. We cannot be responsible for variance of individual knitters or crocheters, human error, or typographical mistakes.

©2013 Lion Brand Yarn Company, all rights reserved.

Cozy Knit Afghans

Half Square Triangle Blanket

By: Lion Brand Design Team



Size: About 32 x 32 in. (81.5 x 81.5 cm)

Materials:

- LION BRAND® JAMIE® (Art. #881)
 - #206 Mardi Gras Stripes 4 balls (A)
 - #157 Sunshine 2 balls (B)
 - #100 Angel White 2 balls (C)
 - or colors of your choice
- LION BRAND® knitting needles size 5 (3.75 mm)
- LION BRAND® large-eyed blunt needle

Gauge: 20 sts + 38 rows = 4 in. (10 cm) in Garter st (k every row).

When you match the gauge in a pattern, your project will be the size specified in the pattern and the materials specified in the pattern will be sufficient. If it takes you fewer stitches and rows to make a 4 in. (10 cm) square, try using a smaller size hook or needles; if more stitches and rows, try a larger size hook or needles.

Abbreviations

k = knit

k2tog = knit 2 together

k3tog = knit 3 together

rep = repeat

sl = slip

st(s) = stitch(es)

Stitch Explanations

kfb (knit in front and back) Knit next st without removing it from left needle, then k through back of same st – 1 st increased.

yo (yarn over)

An increase that also creates a small decorative hole (eyelet) in the fabric, worked as follows:

1. Bring yarn to front, between the needles.
2. Take yarn to back, over the right needle to create the new st.

Notes

1. Blanket is made of 16 Squares. Each Square is worked diagonally beginning at one corner. Sts are increased and then decreased to make Square.
2. Increase half of each Square is worked in one color and decrease half in another color.

SQUARE (make 16 – 8 with B and A, 8 with C and A)

With first color, cast on 3 sts.

Discover inspiration, how-tos, and thousands of free patterns at LionBrand.com.



Jamie®

a versatile, DK weight,
machine-washable
baby yarn in solid
and striping colors



LionBrand.com

Row 1: Sl 1, (k1, yo, k1) in next st, k1 – 5 sts at the end of this row.

Row 2: Sl 1, k to end of row

Row 3: Sl 1, kfb, k to last 2 sts, kfb, k1 – 7 sts.

Rep last 2 rows until you have 55 sts.

Next Row: Sl 1, k to end of row.

Change to 2nd color.

Next Row: Sl 1, k2tog, k to last 3 sts, k2tog, k1 – 53 sts.

Next Row: Sl 1, k to end of row.

Rep last 2 rows until you have 5 sts.

Last Row: Sl 1, k3tog, k1 – 3 sts.

Bind off.

FINISHING

Arrange Squares as shown in Assembly Diagram, matching yarn color placements. Sew Squares into 4 strips of 4 Squares each. Sew strips together to make Blanket.

Weave in ends.

Assembly Diagram

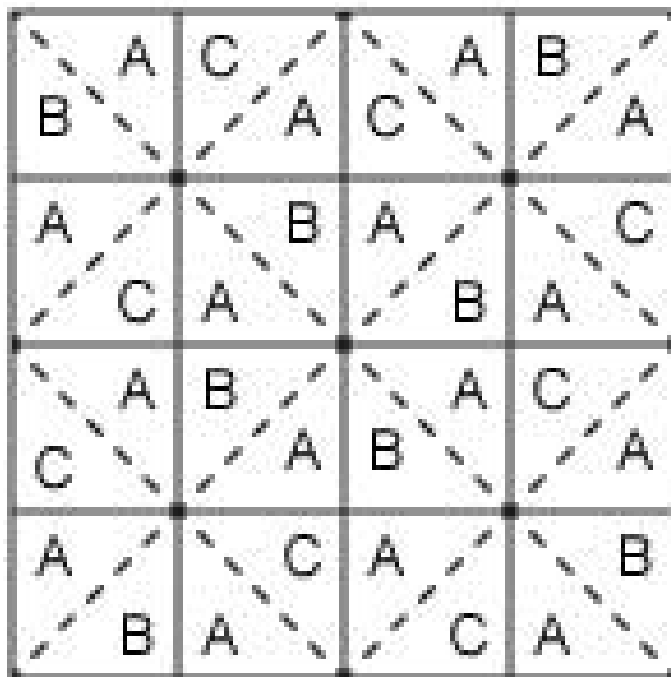

Every effort has been made to produce accurate and complete instructions. We cannot be responsible for variance of individual knitters or crocheters, human error, or typographical mistakes.

©2013 Lion Brand Yarn Company, all rights reserved.

Mountain Mists Afghan

By: Lion Brand Design Team



Size: About 45 x 54 in. (114.5 x 137 cm)

Materials:

- LION BRAND HOMETOWN USA (Art. #135)
 - #170 Las Vegas Gold 3 balls (A)
 - #148 Portland Wine 3 balls (B)
 - #144 Seattle Sea Mist 3 balls (C)
 - #215 Little Rock Granite 3 balls (D)
 - #145 Denver Rocky Mountain 3 balls (E)
 - or colors of your choice
- LION BRAND® knitting needles size 15 (10 mm)
- LION BRAND® large-eyed blunt needle

Gauge: 9 sts + 16 rows = about 4 in. (10 cm) in Garter st (k every row). **BE SURE TO CHECK YOUR GAUGE.**

When you match the gauge in a pattern, your project will be the size specified in the pattern and the materials specified in the pattern will be sufficient. If it takes you fewer stitches and rows to match the gauge, try using a smaller size hook or needles; if more stitches and rows, try a larger size hook or needles.

Notes

1. Five strips are worked separately, then sewed together to make the Afghan.
2. Each Strip is worked in triangle sections created by picking up sts across the previous triangle.
3. When changing color, do not cut old color(s) until instructed. Carry color not in use along side edge of piece, ready for the next time you need it.



Abbreviations

k = knit
k2tog = knit 2 together
k3tog = knit 3 together
p = purl
rem = remain(ing)(s)

rep = repeat
RS = right side
sl = slip
st(s) = stitch(es)
WS = wrong side

STRIP I

Triangle #1

With D, cast on 20 sts.

Row 1 (WS-first stripe): With D, knit.

Change to E.

Row 2 (RS-second stripe): With E, k to last 3 sts, k2tog, p1 – 19 sts at the end of this row.

Row 3: With E, sl 1, k to end of row.

Change to D.

Rows 4 and 5: With D, rep Rows 2 and 3 – 18 sts.

Change to E.

Rows 6-33: Rep last 4 rows 7 times – 4 sts at the end of Row 33.

Row 34: With E, rep Row 2 – 3 sts at the end of this row.

Row 35: With E, k3tog. Do not cut D or E.

Triangle #2

Change to A. Work Triangle #2 with A only.

Set-Up (RS): Pick up and k25 sts evenly spaced across diagonal edge of Triangle #1.

Row 1 (WS): Knit.

Row 2: Sl 1, k2tog, k to last 3 sts, k2tog, k1 – 23 sts.

Row 3: K to last st, p1.

Rows 4-21: Rep last 2 rows 9 times – 5 sts at the end of Row 21.

Row 22: Sl 1, k3tog, k1 – 3 sts.

Row 23: K3tog. Fasten off and cut A.

With RS facing and D, pick up and k20 sts evenly spaced across top edge of Triangle #2.

Rep working Triangle #1 and Triangle #2 alternately until a total of 12 Triangles have been completed. Fasten off.

STRIP II

Make same as Strip I, using D for 1st stripe and C for 2nd stripe of Triangle #1, and B for Triangle #2.

STRIP III

Make same as Strip I, using A for 1st stripe and E for 2nd stripe of Triangle #1, and C for Triangle #2.

STRIP IV

Make same as Strip I, using B for 1st stripe and A for 2nd stripe of Triangle #1, and D for Triangle #2.

STRIP V

Make same as Strip I, using C for 1st stripe and B for 2nd stripe of Triangle #1, and E for Triangle #2.

FINISHING

Sew Strips together in the following order: I, II, III, IV, V.

Weave in ends.

Every effort has been made to produce accurate and complete instructions. We cannot be responsible for variance of individual knitters or crocheters, human error, or typographical mistakes.

©2013 Lion Brand Yarn Company, all rights reserved.

Discover inspiration, how-tos, and thousands of free patterns at LionBrand.com.



Hometown USA®

an easy-care favorite
in bright solid shades,
multicolors, and tweeds,
made in the USA.



LionBrand.com

Slip Stitch Afghan

By: Lion Brand Design Team



Size: 50 x 60 in. (127 x 152.5 cm)

MATERIALS

- LION BRAND WOOL-EASE (Art. #620)
- #159 Mustard 2 balls (A)
- #177 Loden 2 balls (B)
- #179 Chestnut Heather 2 balls (C)
- or colors of your choice
- LION BRAND AMAZING (Art. #825)
- #211 Strawberry Fields 3 balls (D)
- #204 Mesa 3 balls (E)
- #213 Regatta 3 balls (F)
- or colors of your choice
- LION BRAND large-eyed blunt needle
- Circular knitting needle size 9 (5.5 mm), 36 in. (91.5 cm) long

Gauge: 15 sts + 24 rows = 4 in. (10 cm) over pattern.
BE SURE TO CHECK YOUR GAUGE.

When you match the gauge in a pattern, your project will be the size specified in the pattern and the materials specified in the pattern will be sufficient. If it takes you fewer stitches and rows to match the gauge, try using a smaller size hook or needles; if more stitches and rows, try a larger size hook or needles.

Stitch Explanation

Yo (yarn over)

An increase that also creates a small decorative hole (eyelet) in the fabric, worked as follows:

1. Bring yarn to front, between the needles.
2. Take yarn to back, over the right needle. This creates the new st. You are now ready to proceed with the next st as instructed.

Abbreviations

k = knit

p = purl

rep = repeat(s)(ing)

RS = right side

sl = slip

st(s) = stitch(es)

wyib = with yarn in back

wyif = with yarn in front

WS = wrong side

yo = yarn over

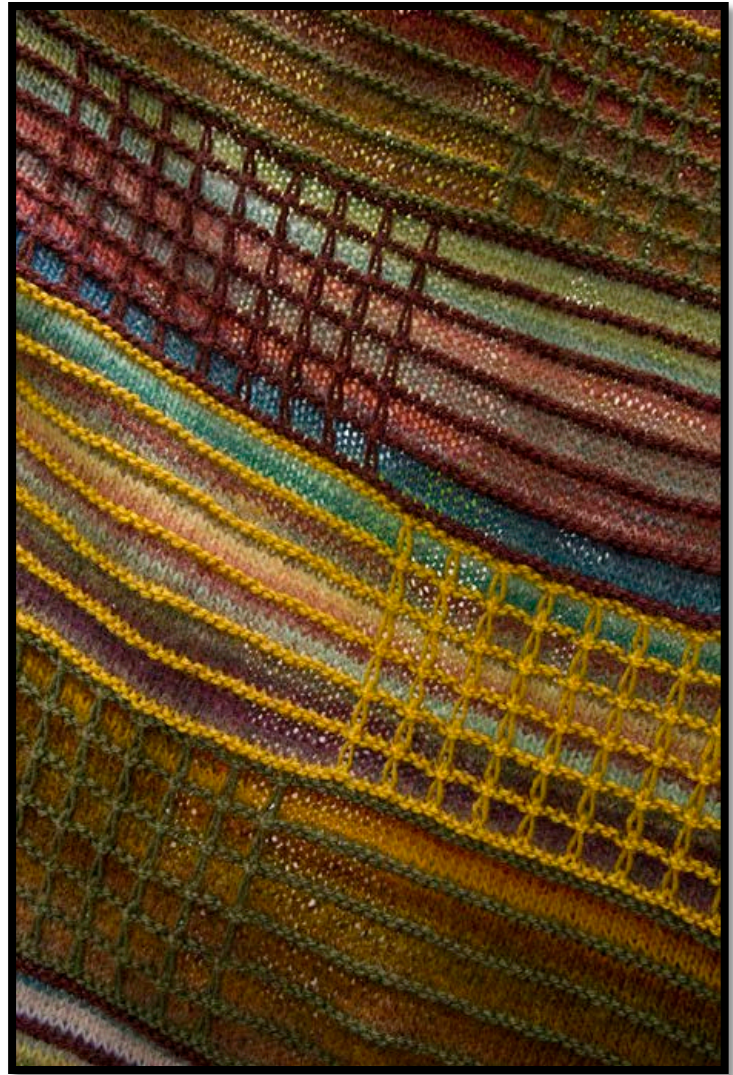

Notes

1. A circular needle is used to accommodate the large number of sts. Work back and forth on the circular needle as if working on straight needles.
2. Afghan is worked in one piece, with 9 sections worked in alternating st and color patterns.
3. Sections 3-9 are repeats of Section 1 or Section 2, changing colors to create a striped effect. With yarn in front (wyif) refers to the side of the work facing you as you work the row; with yarn in back (wyib) refers to the side of the work that is away from you as you work the row.
4. To move yarn from front to back or back to front, bring yarn between needles. Take care not to wrap yarn over a needle, this could create an additional st.
5. Always sl sts as if to purl. On RS rows, sl sts as if to purl with yarn at back; on WS rows, sl sts as if to purl with yarn at front.
6. Only one color is used on each row. Do not cut the unused color between color changes, carry the unused color along the side edge of your work.

AFGHAN

With A, cast on 182 sts.

Border

Knit 3 rows.

Section 1

Row 1 (RS): With A, knit.

Row 2 (WS): With A, k1, *(k3, yo, k1) 9 times, k36; rep from * once more, (k3, yo, k1) 9 times, k1.

Row 3: With D, k1, *(sl 1 wyib, drop yo from needle, k3) 9 times, k36; rep from * once more, (sl 1 wyib, drop yo from needle, k3) 9 times, k1.

Row 4: With D, k1, *(p3, sl 1 wyif) 9 times, p36; rep from * once more, (p3, sl 1 wyif) 9 times, k1.

Row 5: With D, k1, *(sl 1 wyib, k3) 9 times, k36; rep from * once more, (sl 1 wyib, k3) 9 times, k1.

Row 6: Rep Row 4.

Row 7: With A, knit.

Rep Rows 2-7 five more times.

Next Row (WS): With A, knit.

Section 2

Row 1 (RS): With B, knit.

Row 2 (WS): With B, k1, *k36, (k3, yo, k1) 9 times, rep from * once more, k to end of row.

Row 3: With E, k1, *k36, (sl 1 wyib, drop yo from needle, k3) 9 times, rep from * once more, k to end of row.

Row 4: With E, k1, *p36, (p3, sl 1 wyif) 9 times; rep from * once more, p to last st, k1.

Discover inspiration, how-tos, and thousands of free patterns at LionBrand.com.

Sign up for our
FREE newsletter
the **WEEKLY STITCH**



get **inspiration**



check out **how-tos**



discover **great
pattern ideas**

Subscribe at
LionBrand.com!

Row 5: With E, k1, *k36, (sl 1 wyib, k3) 9 times; rep from * once more, k to end of row.

Row 6: Rep Row 4.

Row 7: With B, knit.

Rep Rows 2-7 five times more.

Next Row (WS): With B, knit.

Section 3

Rep Section 1; using C in place of A and F in place of D.

Section 4

Rep Section 2; using A in place of B and D in place of E.

Section 5

Rep Section 1; using B in place of A and E in place of D.

Section 6

Rep Section 2; using C in place of B and F in place of E.

Section 7

Rep Section 1.

Section 8

Rep Section 2.

Section 9

Rep Section 3.

Border

With C, knit 3 rows. Bind off.

FINISHING

Side Borders

With B, pick up and k 232 sts evenly spaced along one long edge of Afghan.

Knit 5 rows. Bind off.

Rep border along opposite long edge of Afghan.

Weave in ends.

Every effort has been made to produce accurate and complete instructions. We cannot be responsible for variance of individual knitters or crocheters, human error, or typographical mistakes.

©2013 Lion Brand Yarn Company, all rights reserved.

Hats, Shawls and Tops

Amazing Mitered Shawl

By: Lion Brand Design Team



Size: Finished Width About 54 in. (127 cm), measured across top edge; **Finished Length** About 27 in. (68.5 cm), measured from back neck to lower center edge

Materials:

- LION BRAND AMAZING (Art. #825)
 - #200 Aurora 2 balls
 - #203 Wildflowers 2 balls
 - #206 Arcadia 1 ball
 - #208 Glacier Bay 1 ball
 - or colors of your choice
- LION BRAND knitting needles size 7 (4.5 mm)
- LION BRAND stitch markers
- LION BRAND large-eyed blunt needle

Gauge: 14 sts + 28 rows = 4 in. (10 cm) in Garter st (k every row). Each Rectangle = 3 x 6 in (7.5 x 15 cm).
BE SURE TO CHECK YOUR GAUGE.

When you match the gauge in a pattern, your project will be the size specified in the pattern and the materials specified in the pattern will be sufficient. If it takes you fewer stitches and rows to match the gauge, try using smaller size needles; if more stitches and rows, try larger size needles.

Notes

1. Shawl is worked, in a modular fashion, from rows of Rectangles. The first row consists of one Rectangle, the second row consists of two Rectangles, the third row consists of three Rectangles and so on. Refer to Assembly Diagram for placement of Rectangles.
2. Each Rectangle is made with two miters (angles) formed by working decreases on every other row.
3. Change colors randomly as desired. To change color, cut the old color leaving an 8 in. (20.5 cm) tail then begin working with the new color leaving a beginning tail. You may knot the old and new yarn tails together, if desired. When you have finished knitting, unknot the yarn tails and weave them in.

Abbreviations

k = knit

k2tog = knit 2 together

k3tog = knit 3 together

rem = remain(ing)

rep = repeat

RS = right side

st(s) = stitch(es)

WS = wrong side



FIRST ROW

Rectangle 1

With desired color, cast on 46 sts.

Row 1 (WS): Knit.

Row 2: K10, k3tog, k1, place marker (pm), k19, k3tog, k1, pm, k9 – 42 sts at the end of this row.

Row 3: Knit.

Row 4: (K to 3 sts before marker, k3tog, remove marker, k1, replace marker) twice, k to end of row – 38 sts.

Rows 5-10: Rep last 2 rows 3 times – 26 sts at the end of Row 10.

Row 11: Knit.

Cut yarn and join new color.

Row 12: Rep Row 4 – 22 sts.

Rows 13-20: Rep Rows 3 and 4 four more times – 6 sts at the end of Row 20.

Row 21: Knit.

Row 22: (K3tog) twice.

Row 23: K2tog.

Fasten off.

SECOND ROW

Rectangle 2

From RS, hold Rectangle 1 with last row at center top of Rectangle. With desired color, cast on 23 sts, working across top of Rectangle 1, pick up and k12 sts evenly spaced across to center of edge, cast on 11 sts – 46 sts.

Rows 1-23: Rep Rows 1-23 of Rectangle 1.

Fasten off.

Rectangle 3

From RS, with desired color, pick up and k11 sts evenly spaced across left side edge of Rectangle 2; working across rem top edge of Rectangle 1, pick up and k12 sts evenly spaced across to corner, cast on 23 sts – 46 sts.

Rows 1-23: Rep Rows 1-23 of Rectangle 1.

Fasten off.

THIRD ROW

Rectangle 4

From RS, with desired color, cast on 23 sts; working across top of first Rectangle of previous row, pick up and k12 sts evenly spaced across to center of edge, cast on 11 sts – 46 sts.

Rows 1-23: Rep Rows 1-23 of Rectangle 1.

Fasten off.

Rectangle 5 (Center Rectangle)

From RS, with desired color, pick up and k11 sts evenly spaced across left side edge of previous Rectangle; working across rem top edge of Rectangle of previous row, pick up and k12 sts evenly spaced across to corner; working across

Discover inspiration, how-tos, and thousands of free patterns at LionBrand.com.



Amazing[®]
a washable, wool-blend
yarn in over 20 rich,
multi-hued colorways



LionBrand.com

top edge of next Rectangle of previous row, pick up and k12 sts evenly spaced across to center of edge, cast on 11 sts – 46 sts.

Rows 1-23: Rep Rows 1-23 of Rectangle 1.

Fasten off.

Rectangle 6

From RS, with desired color, pick up and k11 sts evenly spaced across left side edge of previous Rectangle; working across rem top edge of Rectangle of previous row, pick up and k12 sts evenly spaced across to corner, cast on 23 sts – 46 sts.

Rows 1-23: Rep Rows 1-23 of Rectangle 1.

Fasten off.

FOURTH ROW

Rectangle 7

Work same as Rectangle 4.

Rectangles 8 and 9 (Center Rectangles)

Work two Rectangles, working each the same as Rectangle 5.

Rectangle 10

Work same as Rectangle 6.

FIFTH-NINTH ROWS

Work same as Fourth Row, working one more Center Rectangle in each row.

FINISHING

Weave in ends.

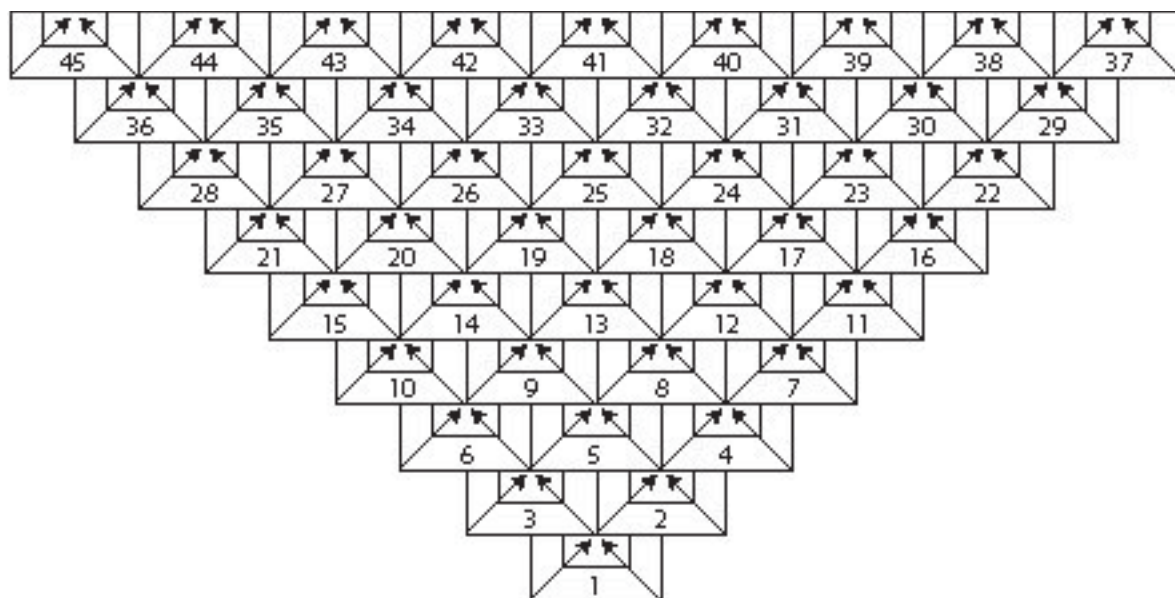

Every effort has been made to produce accurate and complete instructions. We cannot be responsible for variance of individual knitters or crocheters, human error, or typographical mistakes.

©2013 Lion Brand Yarn Company, all rights reserved.

Simple Lace Shawl

By: Lion Brand Design Team



Sizes: About 24 x 60 in. (61 x 152.5 cm), at widest and longest points.

Materials:

- LION BRAND UNIQUE (Art. #755)
 - #204 Moonshadows 2 balls (A)
 - #202 Oceania 2 balls (B)
 - or colors of your choice
- LION BRAND knitting needles size 10 (6 mm)
- LION BRAND large-eyed blunt needle

Gauge: 12 sts + 16 rows = about 4 in. (10 cm) over pattern. When you match the gauge in a pattern, your project will be the size specified in the pattern and the materials specified in the pattern will be sufficient. If it takes you fewer stitches to match the gauge, try using a smaller size hook or needles; if more stitches, try a larger size hook or needles.

Stitch Explanations

M1 (make 1) An increase worked by lifting the horizontal strand lying between needles and placing it onto the left needle. Knit this new stitch through the back loop – 1 st increased.

ssk (slip, slip, knit) Slip next 2 sts as if to knit, one at a time, to right needle; insert left needle into fronts of these 2 sts and knit them tog – 1 st decreased.

Note: Center Panel of Shawl is worked first, then sts are picked up across side edges for left and right panels.

Abbreviations

- beg** = begin(ning)(s)
- k** = knit
- k2tog** = knit 2 together
- k3tog** = knit 3 together
- p** = purl
- p2tog** = purl 2 together

- rem** = remain(ing)(s)
- rep** = repeat
- RS** = right side
- st(s)** = stitch(es)
- yo** = yarn over

SHAWL

Center Panel

With A, cast on 37 sts.

Knit 1 row.

Row 1 (RS): With B, k1, M1, k15, k2tog, k1, ssk, k15, M1, k1.

Row 2: With B, purl.



Row 3: With A, rep Row 1.

Row 4: With A, knit.

Row 5: With B, rep Row 1.

Row 6: With B, k1, *yo, p2tog; rep from * 16 more times, p2.

Rows 7 and 8: With A, rep Rows 3 and 4.

Rep Rows 1-8 until piece measures about 19 in. (48.5 cm) from beg, measuring along center of piece.

With A, knit 2 rows.

Bind off as if to knit. Do not cut yarn.

Left Panel

From RS, pick up and k54 sts evenly spaced across left side edge of Center Panel.

Knit 1 row.

Row 1 (RS): With A, k to last 3 sts, k2tog, k1 – 53 sts.

Row 2: With A, knit.

Row 3: With B, k to last 3 sts, k2tog, k1 – 52 sts.

Row 4: With B, purl.

Rows 5-7: Rep Rows 1-3 – 50 sts at the end of Row 7.

Row 8: With B, k1, *yo, p2tog; rep from * to last st, p1.

Rep Rows 1-8 eleven times – 6 sts.

Rep Rows 1-5 – 3 sts.

Last Row: With A, k3tog.

Fasten off.

Right Panel

From RS, pick up and k54 sts evenly spaced across rem side edge of Center Panel.

Knit 1 row.

Row 1 (RS): With A, k1, ssk, k to end of row – 53 sts.

Row 2: With A, knit.

Row 3: With B, k1, ssk, k to end of row – 52 sts.

Row 4: With B, purl.

Rows 5-7: Rep Rows 1-3 – 50 sts at the end of Row 7.

Row 8: With B, k1, *yo, p2tog; rep from * to last st, p1.

Rep Rows 1-8 eleven times – 6 sts.

Rep Rows 1-5 – 3 sts.

Last Row: With A, k3tog.

Fasten off.

FINISHING

Weave in ends.

Every effort has been made to produce accurate and complete instructions. We cannot be responsible for variance of individual knitters or crocheters, human error, or typographical mistakes.

©2013 Lion Brand Yarn Company, all rights reserved.

Discover inspiration, how-tos, and thousands of free patterns at LionBrand.com.



Unique

a NEW silky-soft,
color-change yarn.

Get these patterns and
more info on our site.



LionBrand.com

Color Waves Tank Top

By: Lion Brand Design Team



Sizes: S (M, L, 1X)

Finished Bust 34 (36, 41, 43) in. (86.5 (91.5, 104, 109) cm)

Finished Length 24 1/2 (26, 25 1/2, 27) in. (62 (66, 65, 68.5) cm)

Note: Pattern is written for smallest size with changes for larger sizes in parentheses. When only one number is given, it applies to all sizes. To follow pattern more easily, circle all numbers pertaining to your size before beginning.

Materials:

- LION BRAND KITCHEN COTTON (Art. #831)
 - #098 Vanilla 2 (2, 3, 3) balls (A)
 - #153 Licorice 1 (1, 2, 2) ball(s) (B)
 - #108 Blue Ice 1 (1, 2, 2) ball(s) (C)
 - #170 Kiwi 1 (2, 2, 2) ball(s) (D)
 - #174 Olive 1 (1, 1, 1) ball (E)
 - #148 Tropic Breeze 1 (2, 2, 2) ball(s) (F)
 - #130 Snap Pea 1 (2, 2, 2) ball(s) (G)
 - #106 Blueberry 1 (1, 1, 1) ball (H)
 - or colors of your choice
- LION BRAND knitting needles size 6 (4.25 mm)
- LION BRAND knitting needles size 7 (4.5 mm)
- LION BRAND knitting needles size 8 (5 mm)
- LION BRAND stitch holders
- LION BRAND large-eyed blunt needle

Gauge: 19 sts + 20 rows = 4 in. (10 cm) over Zigzag pattern with size 7 (4.5 mm) needles (for sizes S and L only); 18 sts + 19 rows = 4 in. (10 cm) over Zigzag pattern with size 8 (5 mm) needles (for sizes M and 1X only). BE SURE TO CHECK YOUR GAUGE. When you match the gauge in a pattern, your project will be the size specified in the pattern and the materials specified in the pattern will be sufficient. If it takes you fewer stitches and rows to match the gauge, try using a smaller size hook or needles; if more stitches and rows, try a larger size hook or needles.

Abbreviations

beg = begin(ning)

k = knit

p = purl

rep = rep

RS = right side

sl = slip

st(s) = stitch(es)

wyib = with yarn in back

wyif = with yarn in front

WS = wrong side

Stitch Explanations

skp Slip 1 as if to knit, knit 1, pass slip stitch over knit stitch – 1 st decreased.

sl2kp (slip 2 sts - k1 st - pass slipped sts over)

A double decrease worked as follows:

1. Insert right needle into next 2 sts as if to knit them tog, and slip them from the left needle to the right needle.
2. Knit the next st.

3. With tip of left needle, lift the 2 slipped sts (the 2nd and 3rd sts on the right needle) up and over the knit st (first st on right needle) and off the needle – 2 sts decreased.

Yo (yarn over)

An increase that also creates a small decorative hole (eyelet) in the fabric, worked as follows:

1. Bring yarn to front, between the needles.
2. Take yarn to back, over the right needle. This creates the new st. You are now ready to proceed with the next st as instructed.

PATTERN STITCH

Zigzag Pattern (worked over a multiple of 8 sts + 1 additional st)

Rows 1 and 2: With B, knit.

Row 3 (RS): With C, k2, yo, k1, *sl2kp, k2, yo, k1, yo, k2; rep from * to last 6 sts, sl2kp, k1, yo, k2.

Row 4: With C, purl.

Rows 5 and 6: With C, rep Rows 3 and 4.

Rows 7-10: With H, rep Rows 3 and 4 twice.

Rows 11 and 12: With A, rep Rows 3 and 4.

Rows 13-16: With F, rep Rows 3 and 4 twice.

Rows 17 and 18: With A, rep Rows 3 and 4.

Rows 19-22: With D, rep Rows 3 and 4 twice.

Rows 23 and 24: With E, knit.

Rows 25-28: With G, rep Rows 3 and 4 twice.

Rep Rows 1-28 for Zigzag pattern.

Notes

1. Tank is made from 2 pieces, Back and Front. Both pieces are worked in ripple and Zigzag patterns.
2. Yo's (yarn overs) are worked with matching decreases so that the stitch count does NOT change in pattern rows.
3. Sizes are created by using different needle sizes for different Tank sizes. Size 7 needles are used for sizes S and L only. Size 8 needles are used for sizes M and 1X only. Size 6 needles are used for armhole edging and neckband for all sizes.
4. The different size needles change the length of the Zigzag section, resulting in the M size being just slightly longer than the L size.
5. With yarn in front (wyif) refers to the side of the work facing you as you work the row; with yarn in back (wyib) refers to the side of the work that is away from you as you work the row.
6. When you see 'as established' in the instructions, this means to continue in the current pattern st, changing color as in pattern and taking care to keep the peaks and valleys of each row aligned.

Discover inspiration, how-tos, and thousands of free patterns at LionBrand.com.



Kitchen Cotton

a classic, worsted weight 100% cotton in bright, retro colors, made in the USA.



LionBrand.com

7. As the stitch and color patterns change and shaping is worked, the current pattern stitches may not always align with the previous pattern stitches.

BACK

With size 7 (4.5 mm) needles for sizes S and L, or size 8 (5 mm) needles for sizes M and 1X and A, cast on 92 (92, 110, 110) sts.

Purl 1 row.

Row 1 (RS): K1, *(k2tog) 3 times, (yo, k1) 6 times, (k2tog) 3 times; rep from * 4 (4, 5, 5) more times, k1.

Row 2: Purl.

Rows 3 and 4: Rep Rows 1 and 2.

Rows 5 and 6: With B, knit.

Rows 7-10: With C, rep Rows 1-4.

Rows 11 and 12: With B, knit.

Rows 13-16: With D, rep Rows 1-4.

Row 17 (Decrease): With E, k1, skp, k to last 3 sts, k2tog, k1 – 90 (90, 108, 108) sts at the end of this row.

Row 18: With E, knit.

Row 19: With F, k1, skp, k3, *(yo, k5) twice, sl2kp, k5; rep from * 3 (3, 4, 4) more times, yo, k5, yo, k4, k2tog, k1.

Row 20: With F, purl.

Rows 21-24: With F, rep Rows 19 and 20 twice.

Row 25 (Decrease): With A, k1, skp, k to last 3 sts, k2tog, k1 – 88 (88, 106, 106) sts.

Row 26: With A, purl.

Row 27: With G, *k3, sl 2 wyib; rep from * to last 3 (3, 1, 1) st(s), k3 (3, 1, 1).

Row 28: With G, p3 (3, 1, 1), *sl 2 wyif, p3; rep from * across.

Rows 29 and 30: With A, rep Rows 25 and 26 – 86 (86, 104, 104) sts at the end of Row 29.

Row 31: With F, k1 (1, 3, 3), *k3, yo, (k2, k2tog) twice, k3, yo; rep from * 5 (5, 6, 6) more times, k1 (1, 3, 3).

Row 32: With F, purl.

Rows 33-36: With F, rep Rows 31 and 32 twice.

Row 37 (Decrease): With H, k1, skp, k to last 3 sts, k2tog, k1 – 84 (84, 102, 102) sts.

Row 38: With H, knit.

Row 39: With C, k0 (0, 3, 3), *(k2tog) twice, (yo, k1) 4 times, (k2tog) twice; rep from * 6 (6, 7, 7) more times, k0 (0, 3, 3).

Row 40: With C, purl.

Rows 41 and 42: With C, rep Rows 39 and 40.

Rows 43 and 44: With A, rep Rows 39 and 40.

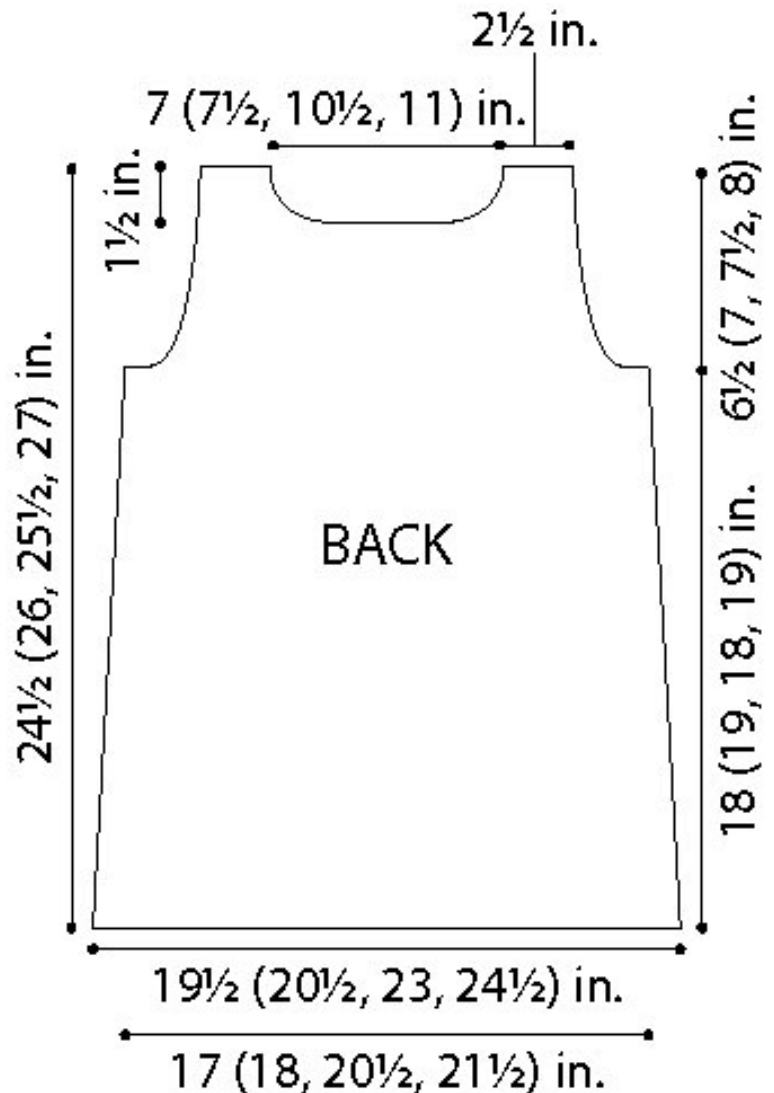

Rows 45 and 46: With D, rep Rows 39 and 40.

Row 47 (Decrease): With E, k1, skp, k to last 3 sts, k2tog, k1 – 82 (82, 100, 100) sts.

Row 48: With E, knit.

Row 49: With G, k6 (6, 9, 9), yo, k3, sl2kp, k3, *yo, k3, yo, k3, sl2kp, k3; rep from * 4 (4, 5, 5) times, yo, k7 (7, 10, 10).

Row 50: With G, purl.

Rows 51 and 52: With G, rep Rows 49 and 50.

Row 53: With A, knit.

Row 54: With A, purl.

Row 55: With B, k3 (3, 2, 2), sl 2 wyib, *k3, sl 2 wyib; rep from * to last 2 (2, 1, 1) st(s), k2 (2, 1, 1).

Row 56: With B, p2 (2, 1, 1), sl 2 wyif, *p3, sl 2 wyif; rep from * to last 3 (3, 2, 2) sts, p3 (3, 2, 2).

Row 57: With A, knit.

Row 58: With A, (p40 (40, 23, 23), p2tog) 1 (1, 3, 3) times, p to end of row – 81 (81, 97, 97) sts.

Row 59: With G, k2, yo, k2tog, *k3, yo, k2tog; rep from * to last 2 (2, 3, 3) sts, k2 (2, 3, 3).

Row 60: With G, purl.

Rows 61 and 62: With G, rep Rows 59 and 60.

Beg Zigzag Pattern

Work Rows 1-28 of Zigzag pattern.

Shape Armholes

Note: As you begin to bind off for armholes, you may need to adjust the Zigzag pattern. When working the RS pattern row, if you do not have a yo before the first sl2kp or after the last sl2kp, change that dec to a skp instead of a sl2kp.

Row 1 (RS): Bind off 6 sts, work in Zigzag pattern as established to end of row – 75 (75, 91, 91) sts.

Row 2: Bind off 6 sts, work in Zigzag pattern as established to end of row – 69 (69, 85, 85) sts.

Row 3: Bind off 2 sts, work in Zigzag pattern as established to end of row – 67 (67, 83, 83) sts.

Row 4: Bind off 2 sts, work in Zigzag pattern as established to end of row – 65 (65, 81, 81) sts.

Row 5 (Decrease): K1, sl2kp, work in Zigzag pattern as established to last 4 sts, sl2kp, k1 – 61 (61, 77, 77) sts.

Row 6: Purl.

Row 7: Rep Row 5 – 57 (57, 73, 73) sts.

Work even in Zigzag pattern as established until armholes measure 5 (5 1/2, 6, 6 1/2) in. (12.5 (14, 15, 16.5) cm), end with a RS row. **Note:** End with a RS row means that the last row you work should be a RS row.

Shape Neck

Row 1 (WS): P39 (39, 55, 55) sts, then sl last 21 (21, 37, 37) sts to a st holder for back neck, join a 2nd ball of yarn and p to end of row – 18 sts rem for each shoulder.

Note: You will now be working both sides at the same time using separate balls of yarn. Wind any single balls of yarn you have into 2 separate balls before beginning.

Row 2: On first side, work in Zigzag pattern as established to end of side; on 2nd side, bind off 4 sts, work in Zigzag pattern as established to end of side.

Row 3: On first side, work in Zigzag pattern as established to end of side; on 2nd side, bind off 4 sts, work in Zigzag pattern as established to end of side – 14 sts on each side.

Row 4: On first side, work in Zigzag pattern as established to end of side; on 2nd side, bind off 3 sts, work in Zigzag pattern as established to end of side.

Row 5: On first side, work in Zigzag pattern as established to end of side; on 2nd side, bind off 3 sts, work in Zigzag pattern as established to end of side – 11 sts on each side.

Row 6: On first side: k1, skp, k2, yo, k1, yo, k2, skp, k1; on 2nd side, k1, skp, k2, yo, k1, yo, k2, skp, k1. Work even in Zigzag pattern as established on both sides using separate balls of yarn until armholes measure 6 1/2 (7, 7 1/2, 8) in. (16.5 (18, 19, 20.5) cm). Bind off.

FRONT

Make same as Back until armholes measure 2 (2 1/2, 3, 3 1/2) in. (5 (6.5, 7.5, 9) cm), end with a RS row – 57 (57, 73, 73) sts.

Shape Neck

Work same as Shape Neck of Back until armholes measure same as Back. Bind off.

FINISHING

Sew left shoulder seam.

Neck Edging

From RS with smallest needles and B, pick up and k15 sts evenly spaced across right side edge of back neck; working over back neck sts on holder, (k2, k2tog) 5 (5, 9, 9) times, k1; pick up and k15 sts evenly spaced across left side edge of back neck; pick up and k22 sts evenly spaced across left side edge of front neck; working over front neck sts on holder, (k2, k2tog) 5 (5, 9, 9) times, k1; pick up and k22 sts evenly spaced across right side edge of front neck – 106 (106, 130, 130) sts.

Purl 1 row.

Bind off as if to purl.

Sew right shoulder, including side edges of edging.

Armhole Edging

With smallest needles and B, pick up and k60 (64, 68, 72) sts evenly spaced along armhole edge.

Purl 1 row.

Bind off as if to purl. Rep along opposite armhole edge. Sew side seams including edges of armhole edging. Weave in ends.

Every effort has been made to produce accurate and complete instructions. We cannot be responsible for variance of individual knitters or crocheters, human error, or typographical mistakes.

©2013 Lion Brand Yarn Company, all rights reserved.

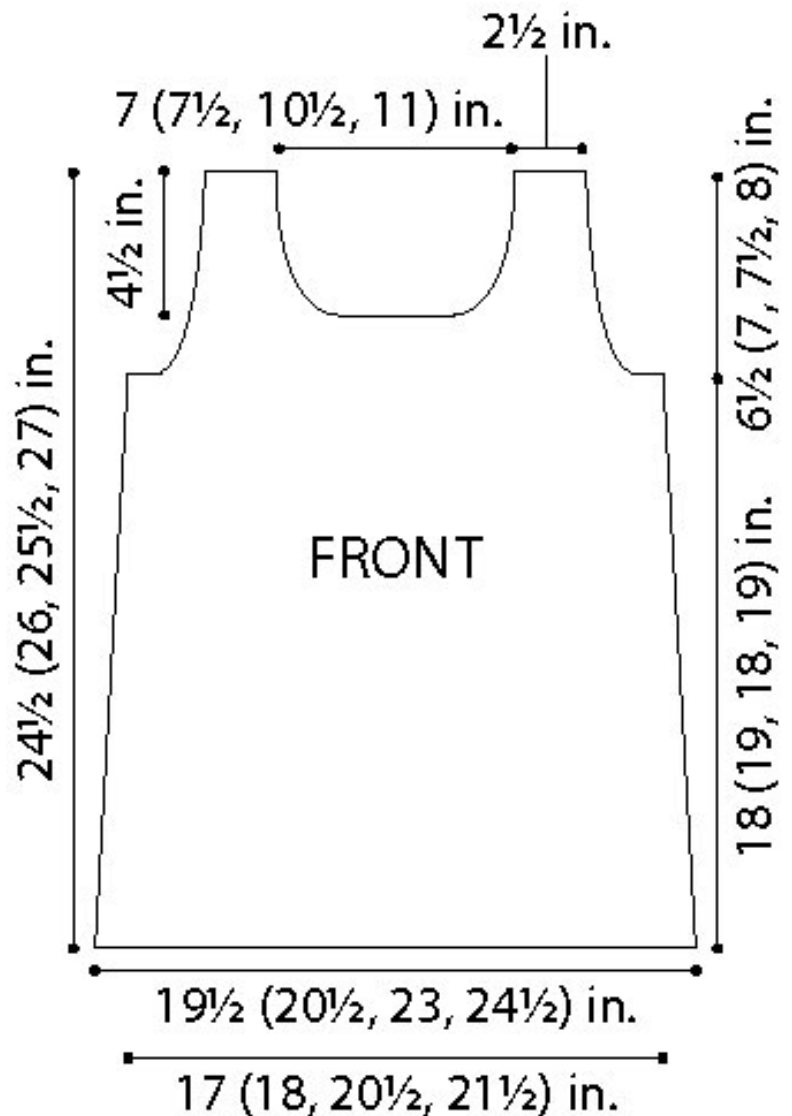

Driggs Avenue Hattitude

By: Lion Brand Design Team



Size: Finished circumference: 20 in. (51 cm). Hat will stretch to fit a range of sizes.

Materials:

- LION BRAND HOMETOWN USA (Art. #135)
 - #150 Chicago Charcoal 1 ball (A)
 - #098 Houston Cream 1 ball (B)
- or colors of your choice
- LION BRAND stitch marker
- LION BRAND large-eyed blunt needle

Additional materials

Double pointed knitting needles size 15 (10 mm), set of 5

Gauge: 9 1/2 sts + 14 rnds = 4 in. (10 cm) in Garter Block pattern. **BE SURE TO CHECK YOUR GAUGE.**

When you match the gauge in a pattern, your project will be the size specified in the pattern and the materials specified in the pattern will be sufficient. If it takes you fewer stitches and rows to match the gauge, try using a smaller size hook or needles; if more stitches and rows, try a larger size hook or needles.

Stitch Explanation

kfb (knit in front and back) Knit next st without removing it from left needle, then k through back of same st – 1 st increased.

Notes

1. Hat is worked in the rnd on double pointed needles.
2. Garter Block st is worked in 2 colors. Carry color not in use across wrong side of work. Pick up new color from under old color.

Abbreviations

beg = begin(ning)(s)

k = knit

p = purl

rep = repeat

rnd(s) = round(s)

st(s) = stitch(es)



HAT

With A, cast on 48 sts. Divide sts onto 4 needles (12 sts per needle). Place marker for beg of rnd. Join by working the first st on the left hand needle with the working yarn from the right hand needle and being careful not to twist sts.

Rnds 1-7: *K2, p2; rep from * around.

Rnd 8: (K2, p2) 4 times, kfb, k1, p2, (k2, p2) 3 times, kfb, k1, p2, (k2, p2) 3 times – 50 sts at the end of this rnd.

Knit 1 rnd.

Beg Garter Block Pattern

Rnds 1 and 3: *With B, k5; with A, k5; rep from * around.

Rnds 2 and 4: *With B, p5; with A, p5; rep from * around.

Rnds 5 and 6: With A, knit.

Rep rnds 1-6 twice more.

With A, knit 1 rnd. Cut A.

Divide sts onto 2 double pointed needles (25 sts on each needle). With RS of work facing outwards, hold both needles in one hand. With 3rd needle and B, *knit together 1 st from each needle; rep from * across – 25 sts at the end of this row.

Working back and forth in rows with B, knit 2 rows.

Bind off as if to knit.

FINISHING

Weave in ends.

Every effort has been made to produce accurate and complete instructions. We cannot be responsible for variance of individual knitters or crocheters, human error, or typographical mistakes.

©2013 Lion Brand Yarn Company, all rights reserved.

Download More Free Project eBooks from Lion Brand



Click on the cover to download your free copy!

Discover inspiration, how-tos, and thousands of free patterns at LionBrand.com.

15% off
your next order on
LionBrand.com

Enter the code
knit1013 at
checkout. Valid
through Oct. 31, 2013

One coupon per person;
cannot be combined
with other coupons.
Valid through Oct. 31, 2013.



Positively Red Hook Hat

By: Lion Brand Design Team



Size: Finished Circumference: About 19 in. (48.5 cm) will stretch to fit a range of sizes.

Materials:

- LION BRAND HEARTLAND (Art. #136)
 - #113 Redwood 1 ball (A)
 - #109 Olympic 1 ball (B)
 - #173 Everglades 1 ball (C)
- or colors of your choice
- LION BRAND double pointed needles size 8 (5 mm), set of 5
- LION BRAND stitch markers
- LION BRAND large-eyed blunt needle
- Circular knitting needle size 8 (5 mm), 16 in. (40.5 cm)

Gauge: 17 sts = about 4 in. (10 cm) in St st worked in the rnd (k every rnd). BE SURE TO CHECK YOUR GAUGE.

When you match the gauge in a pattern, your project will be the size specified in the pattern and the materials specified in the pattern will be sufficient. If it takes you fewer stitches to match the gauge, try using smaller size needles; if more stitches, try larger size needles.

Notes

1. Hat is worked from lower edge up to crown (top of Hat).
2. Hat is worked in the round, beg with a circular needle, then changing to double pointed needles (dpns) when sts have been decreased.
3. If you prefer, the entire Hat can be worked on double pointed needles.
4. When working Stripe Sequence, carry colors not in use up wrong side of work.
5. To prevent a 'jog' when working stripes in the rnd, sl the first st of the second round worked in each new color.

Abbreviations

beg = begin(s)(ning)

k = knit

k2tog = knit 2 together

p = purl

rep = repeat(s)(ing)

rnd(s) = round(s)

st(s) = stitch(es)

St st = Stockinette st

Pattern Stitch

K2, p2 Rib worked in the rnd (over a multiple of 4 sts)

Rnd 1: *K2, p2; rep from * around.

Rep Rnd 1 for K2, p2 Rib worked in the rnd.

Discover inspiration, how-tos, and thousands of free patterns at LionBrand.com.



Heartland

a washable ultra-soft
worsted weight yarn
inspired by the colors of
and made in the USA.



LionBrand.com

STRIPE SEQUENCE

*With A work 4 rnds, with B work 2 rnds, with A work 1 rnd, with C work 4 rnds, with A work 1 rnd, with B work 4 rnds, with C work 2 rnds; rep from * for Stripe Sequence.

Note: When working Stripe Sequence, carry colors not in use up wrong side of work.

HAT

With circular needle and A, cast on 80 sts.

Place marker for beg of rnd. Join by working the first st on left hand needle with the working yarn from the right hand needle and being careful not to twist sts.

Work in K2, p2 Rib worked in the rnd, changing color following Stripe Sequence, until piece measures about 5 1/2 in. (14 cm) from beg.

Change to St st worked in the rnd (k every rnd) and continue in Stripe Sequence until piece measures about 8 1/2 in. (21.5 cm) from beg.

Shape Crown (top of Hat)

Next (Decrease Rnd): *K8, k2tog, rep from * to end of rnd – 72 sts at the end of this rnd.

Next Rnd: Knit, changing to double pointed needles (dpn) as follows: With first dpn, k 18 sts from circular needle, with second, third and fourth dpn, k18 from circular needle. You will have 4 dpn with 18 sts on each.

Next (Decrease Rnd): *K7, k2tog, rep from * to end of rnd – 64 sts at the end of this rnd.

Next Rnd: Knit.

Next (Decrease Rnd): *K6, k2tog, rep from * to end of rnd – 56 sts.

Next Rnd: Knit.

Next (Decrease Rnd): *K5, k2tog, rep from * to end of rnd – 48 sts.

Next Rnd: Knit.

Next (Decrease Rnd): *K4, k2tog, rep from * to end of rnd – 40 sts.

Next Rnd: Knit.

Next (Decrease Rnd): *K3, k2tog, rep from * to end of rnd – 32 sts.

Next Rnd: Knit.

Next (Decrease Rnd): *K2, k2tog, rep from * to end of rnd – 24 sts.

Next Rnd: Knit.

Next (Decrease Rnd): *K1, k2tog, rep from * to end of rnd – 16 sts.

Next Rnd: Knit.

Next (Decrease) Rnd: *K2tog; rep from * to end of rnd – 8 sts.

Cut yarn, leaving a long tail. Thread tail through remaining sts and pull to gather. Knot securely.

FINISHING

Weave in ends.

Every effort has been made to produce accurate and complete instructions. We cannot be responsible for variance of individual knitters or crocheters, human error, or typographical mistakes.

©2013 Lion Brand Yarn Company, all rights reserved.